

TECHNICAL INFORMATION MANUAL

Revision 3 – 01 April 2021

R4320P

Proton

Industrial 4-port RAIN RFID Long Range Reader



Visit the [Proton R4320P web page](#), you will find the latest revision of data sheets, manuals, certifications, technical drawings, software and firmware. All you need to start using your reader in a few clicks!

Scope of Manual

The goal of this manual is to provide the basic information to work with the Proton R4320P Industrial 4-port RAIN RFID Long Range Reader.

This manual refers to:

- Proton R4320P firmware revision $\geq 1.2.0$
- [SDK \(Software Development Kit\)](#) revision $\geq 4.7.0$

Change Document Record

Date	Revision	Changes	Pages
30 Nov 2018	00	Preliminary Release	-
05 Nov 2019	01	Added <i>CE Declaration of Conformity</i>	61
		Modified <i>Ordering Options</i> table	9
		Modified <i>Ethernet Port</i> paragraph	17
08 Jan 2020	02	Added <i>FCC Compliance</i> paragraph and <i>Proton FCC Grant</i>	61
01 Apr 2021	03	Graphic Restyling	All pages
		Added <i>Installation Notice</i> paragraph	10
		Added <i>HID Profile</i> chapter	49
		Added <i>Technical Drawings</i> paragraph	56
		Added <i>Connecting to RA0003 Multiplexer</i> chapter	58
		Modified <i>Regulatory Compliance</i> chapter	61

Reference Document

- [RD1] EPCglobal: EPC Radio-Frequency Identity Protocols Class-1 Generation-2 UHF RFID Protocol for Communications at 860 MHz – 960 MHz, Version 2.0.1 (April, 2015).
- [RD2] CMC Centro Misura Compatibilità S.r.l. - Report Federal Communication Commission (FCC) – Proton R4320P –Long range RAIN RFID reader. Test report n. R19237901 Rev. 1.0 – 11 Dec 2019
- [RD3] CMC Centro Misura Compatibilità S.r.l. - Report Federal Communication Commission (FCC) – Proton R4320P –Long range RAIN RFID reader. Test report n. R19238001 Rev. 1.0 – 29 Nov 2019

CAEN RFID srl

Via Vetraia, 11 55049 Viareggio (LU) - ITALY
Tel. +39.0584.388.398 Fax +39.0584.388.959
info@caenrfid.com
www.caenrfid.com

© CAEN RFID srl – 2021

Disclaimer

No part of this manual may be reproduced in any form or by any means, electronic, mechanical, recording, or otherwise, without the prior written permission of CAEN RFID.

The information contained herein has been carefully checked and is believed to be accurate; however, no responsibility is assumed for inaccuracies. CAEN RFID reserves the right to modify its products specifications without giving any notice; for up to date information please visit www.caenrfid.com.

Federal Communications Commission (FCC) Notice

This device was tested and found to comply with the limits set forth in Part 15 of the FCC Rules. Operation is subject to the following conditions: (1) this device may not cause harmful interference, and (2) this device must accept any interference received including interference that may cause undesired operation. These limits are designed to provide reasonable protection against harmful interference when the equipment is operated in a commercial environment.

This device generates, uses, and can radiate radio frequency energy. If not installed and used in accordance with the instruction manual, the product may cause harmful interference to radio communications. Operation of this product in a residential area is likely to cause harmful interference, in which case, the user is required to correct the interference at their own expense. The authority to operate this product is conditioned by the requirements that no modifications be made to the equipment unless the changes or modifications are expressly approved by CAEN RFID.

Disposal of the product

Do not dispose the product in municipal or household waste. Please check your local regulations for disposal/recycle of electronic products.

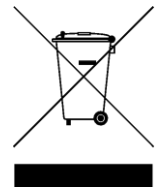

Index

	Scope of Manual	2
	Change Document Record	2
	Reference Document	2
1	Introduction	7
	Description	7
	Development Kit	8
	Ordering Options	9
	Installation Notice	10
2	Getting Started	11
	Introduction	11
	Connecting to the Proton Reader using the Ethernet port	11
	Ethernet Communication Setup	11
	Easy Controller	12
3	External Interface Description	14
	LEDS	14
	Connectors	15
	Power Supply	15
	Ethernet Port	17
	GPIO/Serial	18
	RS232 Communication	21
	Antennas	22
4	Configuration Using the Web Interface	24
	Introduction	24
	NETWORK	26
	SYSTEM	27
	RFID	28
	Profile	28
	Easy2read Configuration Options	29
	HID Configuration Options	31
	Custom Configuration Options	38
	INFO	40
5	EASY2READ Profile	41
	Introduction	41
	Connecting using the Ethernet port	41
	Ethernet Communication Setup	41
	Easy Controller	42
	Connecting using the serial port	44
	Serial Communication Setup	44
	Easy Controller	44
	Inventory on GPIO state change	47
6	HID Profile	49
	Introduction	49
	Connecting using the Ethernet port	49
	Ethernet Communication Setup	49
	Connecting using the serial port	50
	Serial Communication Setup	50
7	CUSTOM Profile	51
	Introduction	51
	Java Virtual Machine	51
8	Reader Reset	52
9	Firmware Upgrade	53
10	Technical Specifications	55
	Technical Specifications Table	55
	Technical Drawings	56
11	Connecting to RA0003 Multiplexer	58
	RA0003 Multiplexer	58

	Proton R4320P – RA0003 Multiplexer Connection.....	59
12	Regulatory Compliance.....	61
	CE Compliance.....	61
	FCC Compliance.....	61
	RoHS EU Directive	62
	Proton R4320P CE DECLARATION OF CONFORMITY	63
	Proton R4320P FCC Grant.....	64

List of Figures

Fig. 1.1: Proton reader (Model R4320P)	7
Fig. 1.2: Proton R4320P Accessories Kit	8
Fig. 1.3: Proton R4320P Technical drawings: top view	10
Fig. 3.1: Proton R4320P LEDs	14
Fig. 3.2: Proton R4320P Interfaces Panel	15
Fig. 3.3: Power Supply connector (reader side)	15
Fig. 3.4: Power Connector PHOENIX 1543029	16
Fig. 3.5: Phoenix 1543029 connector	16
Fig. 3.6: Ethernet Connector (reader side)	17
Fig. 3.7: GPIO/Serial Connector (reader side)	18
Fig. 3.8: GPIO Input Signal	19
Fig. 3.9: GPIO Output Signal	21
Fig. 3.10: Example of a serial connection between the reader and a PC	21
Fig. 3.11: Example of a serial connection between the reader and a PC using a USB/RS232 converter	22
Fig. 3.12: Proton R4320P Antennas	22
Fig. 4.1: Proton R4320P Web Interface	25
Fig. 10.1: Proton R4320P Technical Drawings – 3D view	56
Fig. 10.2: Proton R4320P Technical Drawings	57
Fig. 11.1: RA0003 UHF Antenna Multiplexer	58
Fig. 11.2: Proton reader – RA0003 MUX Connection- case 1	59
Fig. 11.3: Proton reader – RA0003 MUX Connection – case 2	60

List of Tables

Tab. 1.1: Cylindrical-head self-tapping screw measures	10
Tab. 3.1: Proton R4320P LEDs	14
Tab. 3.2: Proton R4320P Interfaces Panel	15
Tab. 3.3: Proton R4320P - Power Supply Connector Poles	15
Tab. 3.4: PHOENIX CONTACT: 1543029 Poles	16
Tab. 3.5: Proton R4320P - Ethernet Connector Poles	17
Tab. 3.6: Proton R4320P - Ethernet Connector LEDS	17
Tab. 3.7: Proton R4320P – GPIO/Serial Connector Poles	18
Tab. 3.8: Proton R4320P Antennas	22
Tab. 4.1: Conducted power	30
Tab. 4.2: Conducted power	32
Tab. 4.3: EPC Code parameters	34
Tab. 4.4: Escape Sequences supported	35
Tab. 4.5: Conducted power	39
Tab. 10.1: Proton R4320P Technical Specifications	55

1 INTRODUCTION

Description

The Proton (Model R4320P) is a rugged long range RAIN RFID reader of the easy2read[®] product line, well suited for industrial environment installations.

The Proton reader has 4 antenna ports capable of a 31.5 dBm maximum power enabling to build RAIN RFID portals for logistic. Its compact form factor makes it easy to install and the IP65 protection permits outdoor or harsh environment installations. Featuring Power Over Ethernet, RS232 and GPIOs via industry standard M12 connectors the Proton is an ideal choice for industrial automation and Industry 4.0 solutions.

The Proton is based upon an embedded Linux platform and it's easily configurable using an internal web interface. System integrators can customize the behaviour of the reader installing Java code that, having access to all the RFID features and interfaces, permits a full customization.

The Proton reader complies with and can operate in both European and US regulatory environments and, due to its multiregional capabilities, it's ideal for integration in devices requiring compliance to different geographical regions.



Fig. 1.1: Proton reader (Model R4320P)

Development Kit

A development kit with adapter, antennas, cable and demo tags is available:



Fig. 1.2: Proton R4320P Accessories Kit

The kit includes:

- n. 1 [A927Z Temperature Logger Tag](#)
- n. 1 [RT0005 Temperature Logger Tag](#)
- n. 1 [Set of Labels](#)
- n. 1 [WANTENNAX019](#) (ETSI) or [WANTENNAX020](#) (FCC) Circular polarized antenna
- n. 1 WALIM0000006 (EU) or WALIM0000007 (US) power supply for Proton R4320P Reader.
- n.1 WCAVOAAAX005 antenna cable
- n. 1 ECCANTRFX033 Ethernet cable (5 m)

The Proton R4320P reader and its development kit are a complete set up for a quick implementation of RFID solutions.

Ordering Options

	Code	Description
Reader	WR4320PXAAAA	R4320P Proton - Industrial 4-port RAIN RFID Long Range Reader
Development kit	WR4320PXDKEU	Proton - ETSI Dev Kit including RFID antenna with cable, power supply, Ethernet cable and tag samples (reader not included)
	WR4320PXDKUS	Proton - FCC Dev Kit including RFID antenna with cable, power supply, Ethernet cable and tag samples (reader not included)
Accessories	WALIM0000006	R4320P – Auxiliary Power Supply - EU
	WALIM0000007	R4320P – Auxiliary Power Supply - US
	WANTENNAX019	Circular polarized antenna 8.5dBc – ETSI
	WANTENNAX020	Circular polarized antenna 8.5dBc – FCC
	WCAVOAAAX005	Antenna RF cable with TNC/RP-N connectors
	ECCANTRFX033	Ethernet cable (5 m)

Installation Notice

The Proton R4320P reader could be mounted either horizontally or vertically. Locate the four mounting slots on the reader, as illustrated in *Fig. 1.3: Proton R4320P Technical drawings: top view*. In the four mounting slots there are rubber gaskets to facilitate adherence to smooth surfaces.

All measurements are in millimetres.

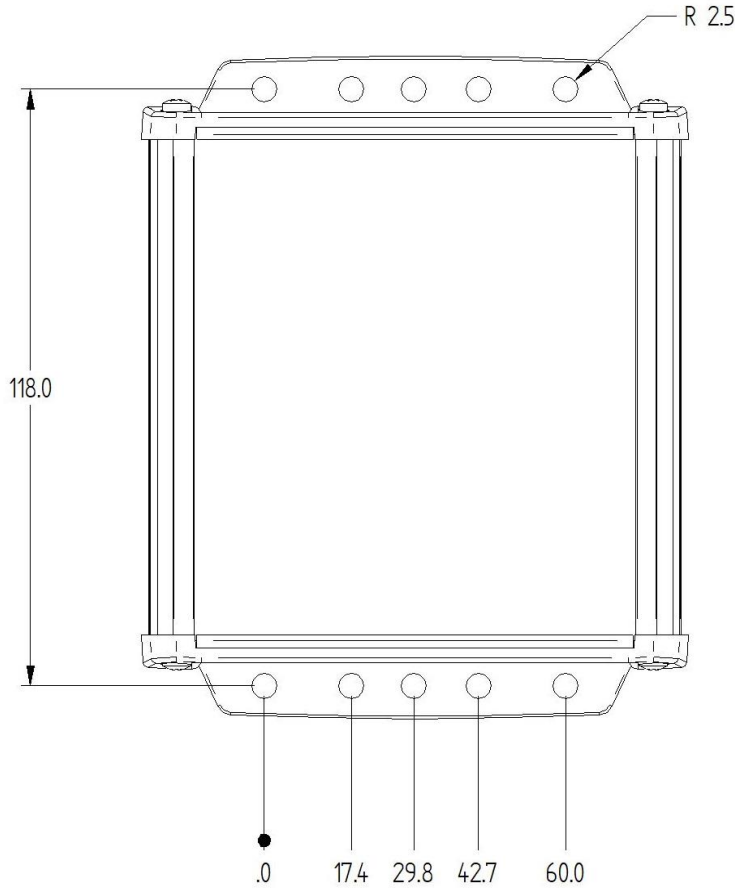
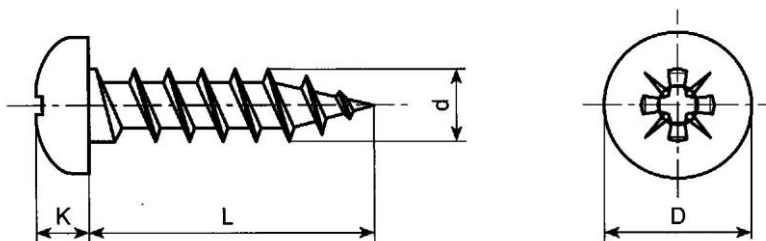

Fig. 1.3: Proton R4320P Technical drawings: top view

Wall fixing

A cylindrical-head self-tapping screw (not provided) with the following measures is recommended to fix the reader directly to the wall:



where:

Parameter	Min value	Max value	Unit
K	1	4	mm
L	50	100	mm
d	3	5	mm
D	6	10	mm

Tab. 1.1: Cylindrical-head self-tapping screw measures

2 GETTING STARTED

Introduction

This quickstart guide will help you to get started with your Proton (Model R4320P) reader.

The reader can be configured in three different profiles:

- **EASY2READ** (factory default): choosing this option you select the CAEN RFID easy2read communication protocol. Select this option in order to control the reader using the [CAEN RFID Easy Controller Application](#) or the [SDK \(Software Development Kits\)](#) library. For details on the use of the EASY2RD profile please refer to this quickstart guide.
- **HID**: choosing this option you select the keyboard emulation protocol.
For details on the use of the HID profile please refer to § *HID Profile* chapter page 49.
- **CUSTOM**: the use of this profile allows the user to upload their own scripts to the reader. For details on the use of the Custom profile please refer to § *CUSTOM Profile* page 51.

The reader is sold with the factory profile set to *EASY2READ*. This guide helps you to getting started with your reader using the EASY2READ profile.

For more detailed information on reader configuration, connections and setup options please refer to the next chapters.

Connecting to the Proton Reader using the Ethernet port

Ethernet Communication Setup

The Proton reader can be connected to a PC using an Ethernet cable. In order to correctly operate with the reader follow the steps above:

1. Connect the Proton to the power supply, the power LED will turn on, wait about 30 seconds until you hear a beep, wait 10 seconds again and the reader is ready to work with the *easy2read* profile active.
2. Plug an Ethernet cable (not provided, see § *Ordering Options* page 9) into your computer and connect the other end of the Ethernet cable to the reader. By default, the Proton reader is configured with the static IP address 192.168.0.2. If your private network matches the default network configuration of the reader you can connect to it. Otherwise you can either change the network configuration of the reader (see § *NETWORK* page 26) to connect it to your network or disconnect your PC from your network and connect it to the network of the reader.
3. Connect the antenna cable to Ant-0 (see § *Fig. 3.12: Proton R4320P Antennas* page 22) of the reader.

Now you can use the [CAEN RFID Easy Controller](#) Application to control the reader.

Easy Controller

Follow these steps to connect the Proton using the *Easy Controller* application for Windows:

1. Download the latest version of the *Easy Controller software* from the [Proton R4320P web page](#), *Downloads* section and install it.
2. Launch the *Easy Controller* application:

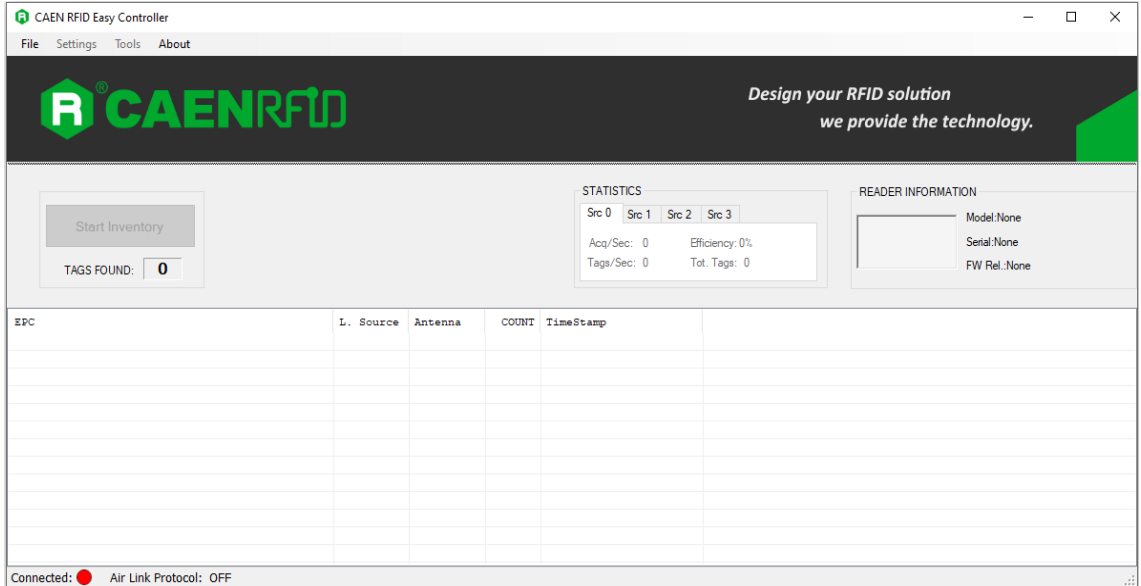

3. On the main screen click on *File* → *Connect*. A Connection windows will open. Select the *Connection Type* (TCP/IP Connection) and type the Proton IP address into the *TCP/IP Address* box (default value is 192.168.0.2). Then click on *Connect*:

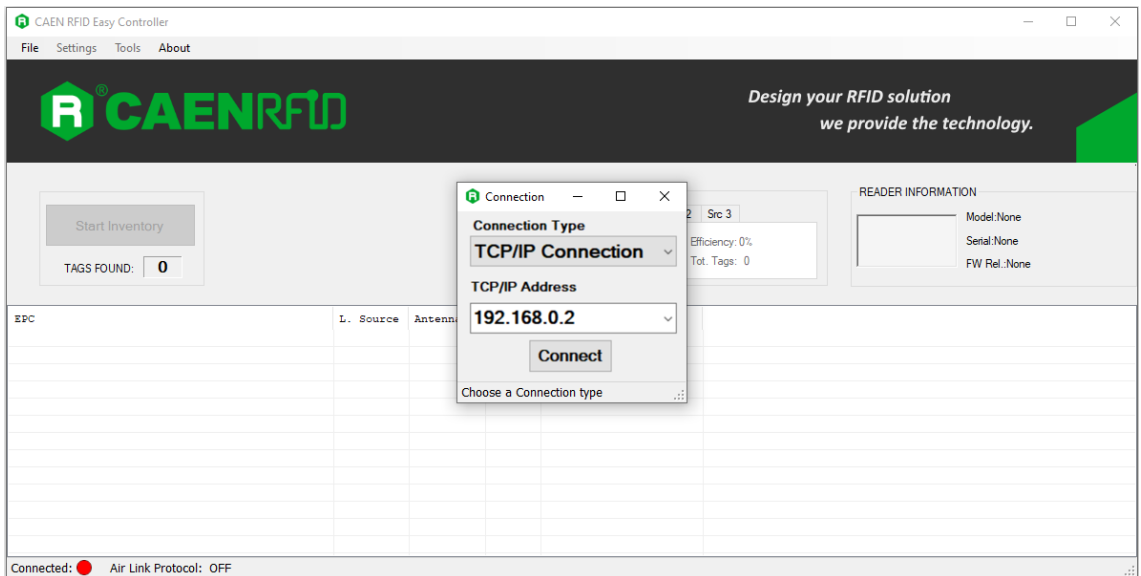

- To verify if the connection with the reader has been established, check the green dot on the bottom left side of the sidebar. Into the *READER INFORMATION* box you can find information on reader model, serial number and firmware release:

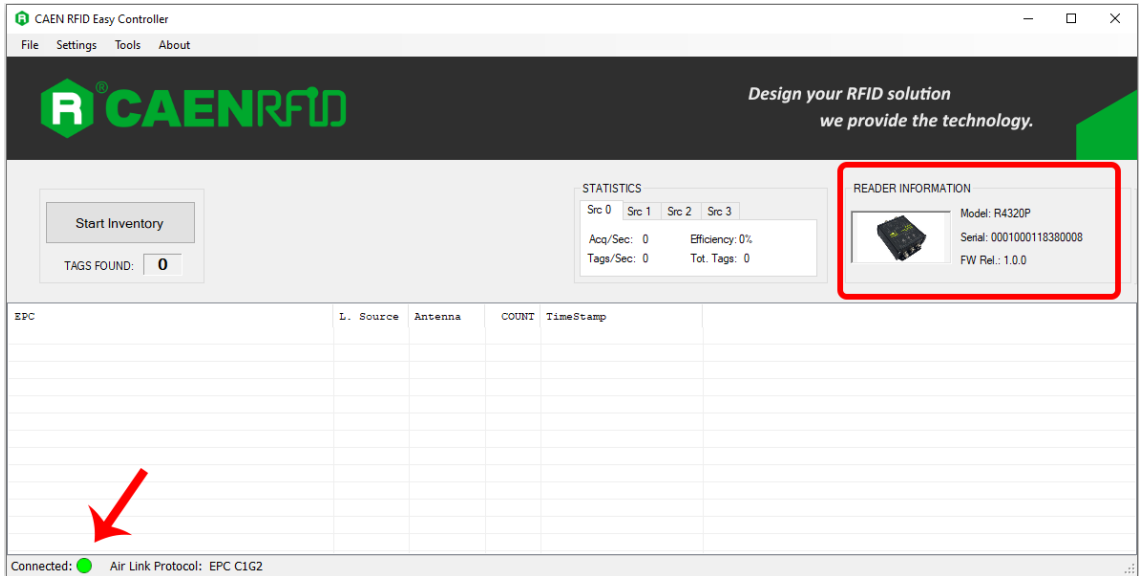

- Place a tag on the read range of the reader, click on *start inventory* and see the tag information displayed on the main window:

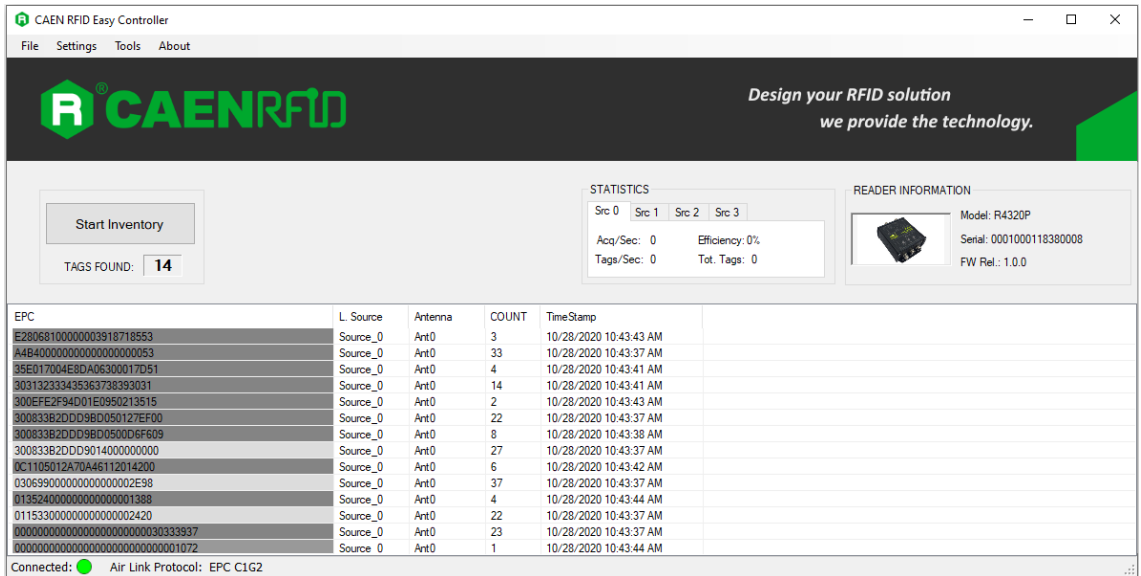

For more info on the use of the *Easy Controller*, please refer to the *CAEN RFID Easy Controller Software Technical Information Manual*, you can download it from the [Proton R4320P web page](#), Downloads section or in the [Manual and Documents](#) web area.

3 EXTERNAL INTERFACE DESCRIPTION

LEDS

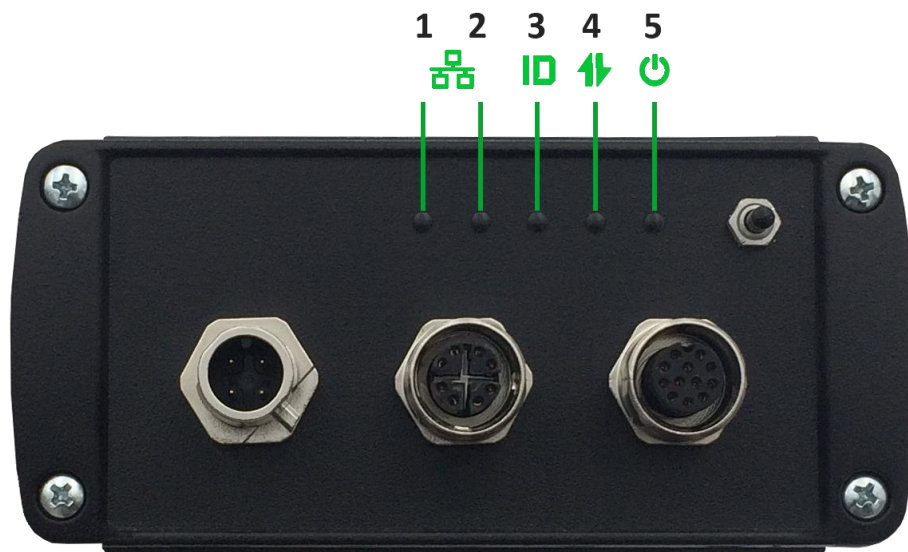

Fig. 3.1: Proton R4320P LEDs

No.	Name	Description
1	ETH Network activity	Yellow LED (see § Tab. 3.6: Proton R4320P - Ethernet Connector LEDS page 17)
2	ETH Speed connection	Yellow/Green LED (see § Tab. 3.6: Proton R4320P - Ethernet Connector LEDS page 17)
3	Tag-ID	Tag Detection – Blinking Red LED
4	Communication	Communication activity – Blinking Yellow LED
5	Power	Power On – Green LED

Tab. 3.1: Proton R4320P LEDs

Connectors

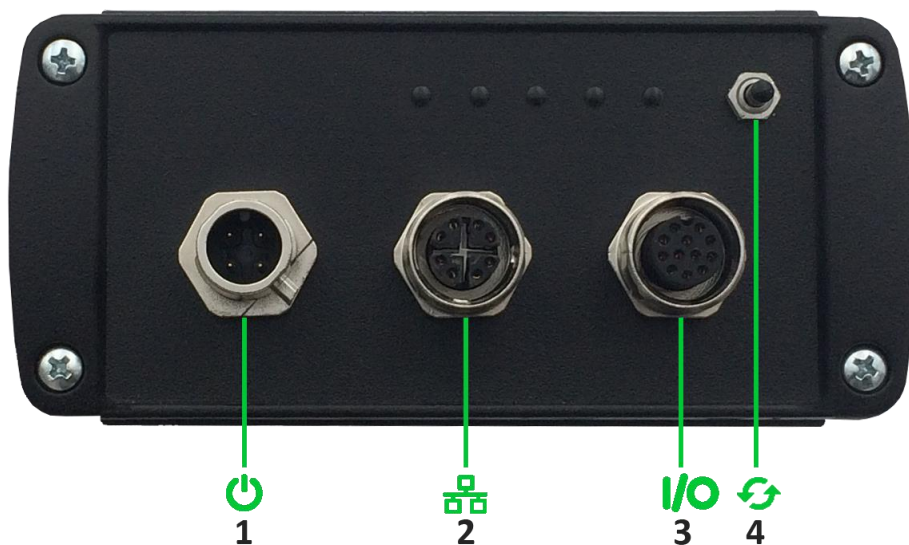

Fig. 3.2: Proton R4320P Interfaces Panel

No.	Name	Description
1	Power	Power Supply Connector
2	Ethernet	Ethernet 10/100/1000BASE-T (M12) / POE standard IEEE 802.3af
3	GPIO	General Purpose Input Output / RS232 (Tx/Rx signal)
4	RESET/UPGRADE	Restart device / Upgrade operative system

Tab. 3.2: Proton R4320P Interfaces Panel

Power Supply

The power supply connector shall be used to provide the Proton R4320P with the DC supply voltage in the range 9V÷36V. A recommended part number for coupling with the connector of the reader is the PHOENIX CONTACT: 1543029 (not provided, to be used on the supply voltage cable).

M12, 4-pin, A-coded, Male

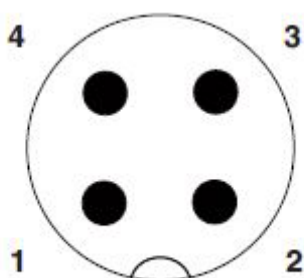

Fig. 3.3: Power Supply connector (reader side)

Pin #	Signal	Function
1	VDC	Positive pole
2	N.C.	Not Connected
3	GND	Ground
4	N.C.	Not Connected

Tab. 3.3: Proton R4320P - Power Supply Connector Poles

Power Supply Connector

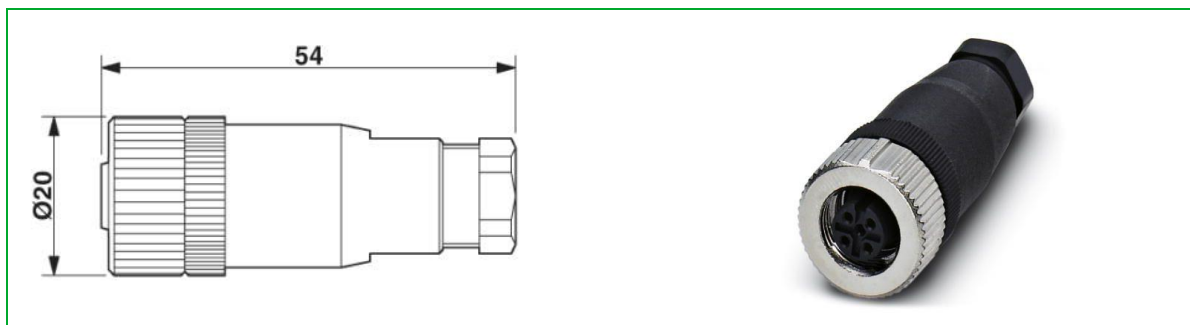

Fig. 3.4: Power Connector PHOENIX 1543029

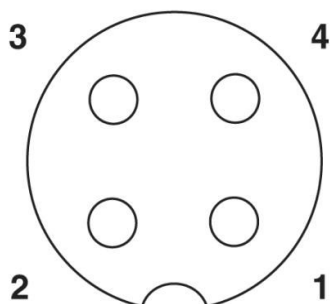

Fig. 3.5: Phoenix 1543029 connector

Pin #	Signal	Function
1	VDC	Positive pole
2	N.C.	Not Connected
3	GND	Ground
4	N.C.	Not Connected

Tab. 3.4: PHOENIX CONTACT: 1543029 Poles



Warning: To guarantee the IP65 degree of the device it is necessary that the male connector on the reader is coupled with the female one on the cable. If the male connector is free, a protective cap must be applied to guarantee the IP65 degree. The following part number is recommended: sealing cap PHOENIX 1560251.

Ethernet Port

The Ethernet interface of the Proton R4320P can be used to connect the reader to a 10/100/1000BaseT network using a M12 to RJ45 cable.

The Proton R4320P reader supports Power Over Ethernet (POE) standard IEEE 802.3 af.

The pinout of the connector is shown in the following figure:

M12, 8-pin, X-coded, Female

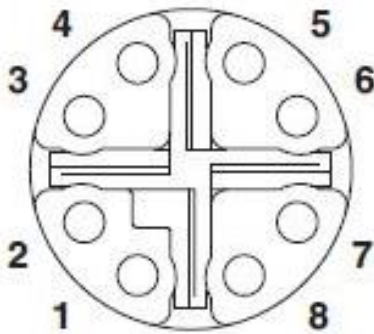

Fig. 3.6: Ethernet Connector (reader side)

Pin #	Signal	Function
1	TX+	Trasmission positive
2	TX-	Trasmission negative
3	RX+	Receive positive
4	RX-	Receive Negative
5	POWER-	POWER-
6	POWER-	POWER-
7	POWER+	POWER+
8	POWER+	POWER+

Tab. 3.5: Proton R4320P - Ethernet Connector Poles

The Ethernet connector has two LEDs with the following functionalities:

LED	Function	Type
Left	Network activity	Blinking Yellow
Right	10Mbps connection	OFF
Right	100Mbps connection	Yellow
Right	1000Mbps connection	Green

Tab. 3.6: Proton R4320P - Ethernet Connector LEDs

An Ethernet Cable (ECCANTRFX033) is available (not provided with the reader): see *Ordering Options* page 9.

Otherwise we suggest to use the following product:

- Network cable (5m) - NBC-MSX/ 5,0-94F/R4AC SCO – 1407473 PHOENIX CONTACT

Ethernet cable shall be CAT6 at least (type S/FTP or S/STP) for proper operation of the device.



Warning: To guarantee the IP65 degree of the device it is necessary that the female connector on the reader is coupled with the male one on the cable. If the female connector is free, a protective cap must be applied to guarantee the IP65 degree. The following part number is recommended: Sealing cap PHOENIX 1680539.

GPIO/Serial

The GPIO/Serial interface of the Proton R4320P is used to connect the reader with a standard RS232 serial communication and to provide the signals of 2 inputs and 2 outputs to the reader. The inputs are usually connected to devices (photocells, sensors ..) that enable the tag inventory. The outputs instead usually turn on accessory devices, following a pre-established event (sirens, flashing lights...).

M12, 12-pin, A-coded, Female

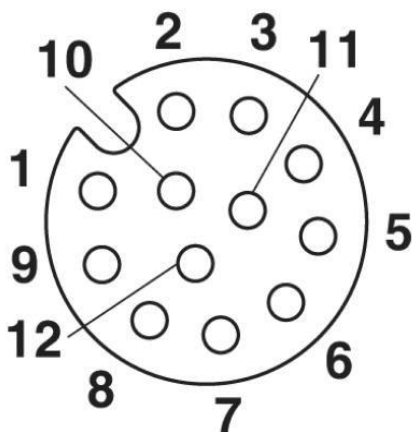

Fig. 3.7: GPIO/Serial Connector (reader side)

Pin #	Signal	Function
1	RS232_RX	RS232 receive signal
2	OUTPUT2.2	SS-Relay 2 Contact 2
3	OUTPUT2.1	SS-Relay 2 Contact 1
4	OUTPUT1.2	SS-Relay 1 Contact 2
5	OUTPUT1.1	SS-Relay 1 Contact 1
6	GND	Ground
7	RTN	Return
8	V_INT	Internal voltage ¹
9	RS232_TX	RS232 transmit signal
10	GPI0	General purpose input 0
11	GPI1	General purpose input 1
12	RTN	Return

Tab. 3.7: Proton R4320P – GPIO/Serial Connector Poles

A GPIO/Serial Cable is not provided. We suggest to use the following products:

- Sensor/Actuator cable (1,5 m)- SAC-12P-MS/ 1,5-35T SH SCO - 1430048 shielded
- Sensor/Actuator cable (1,5 m) - SAC-12P-MS/ 1,5-PVC SCO - 1554775
- Sensor/Actuator cable (3 m) - SAC-12P-MS/ 3,0-35T SH SCO - 1430051 shielded
- Sensor/Actuator cable (3 m) - SAC-12P-MS/ 3,0-PVC SCO - 1554788



Warning: To guarantee the IP65 degree of the device it is necessary that the female connector on the reader is coupled with the male one on the cable. If the female connector is free, a protective cap must be applied to guarantee the IP65 degree. The following part number is recommended: Sealing cap PHOENIX 1680539.

¹ When powered by a power supply, the internal voltage is equal to the supply voltage. When powered by POE, internal voltage is 5V.

Input signal

To have a valid input signal, apply a voltage between 4V and 48V to the pin indicated by GPIO or GPI1

Using the signals on the connector you can connect the Internal Voltage pin to the GPIO pin through a switch that enables the input signal when closed.

A connection between GND ground and RTN signal is also required:

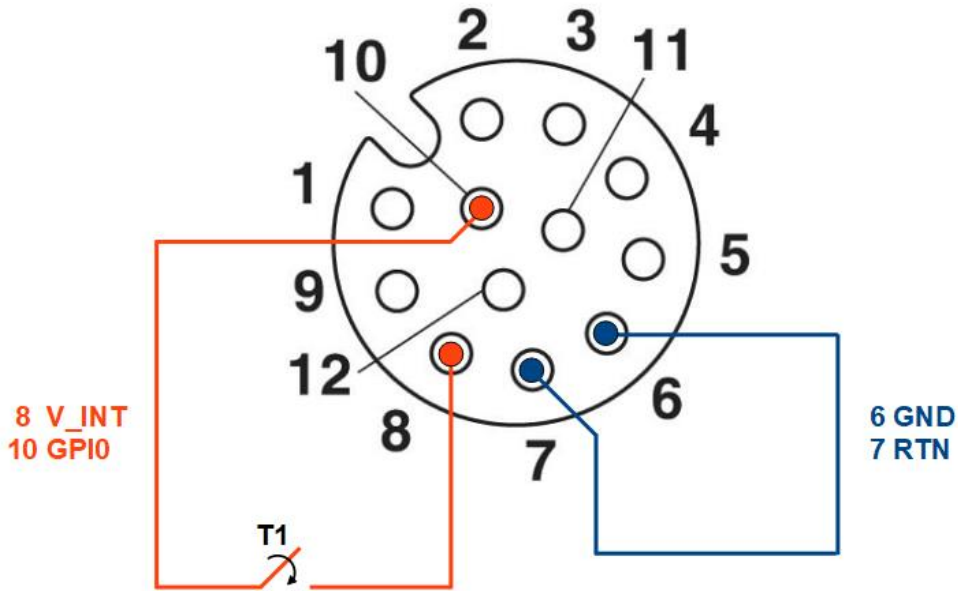
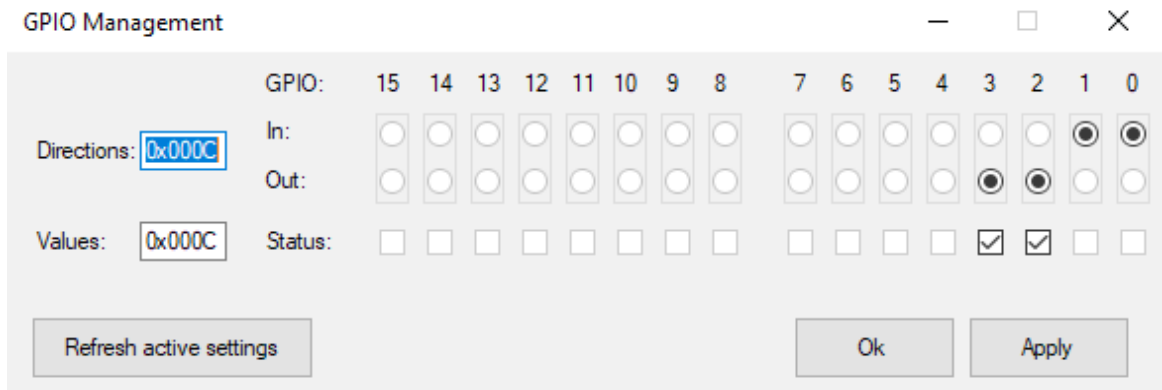

Fig. 3.8: GPIO Input Signal

It is possible to verify the correct functioning of the circuit by connecting the reader to the CAEN RFID Easy Controller software, Tools-I/O management section:

GPIO corresponds to GPIO0 of the Easy Controller software

GPI1 corresponds to GPIO1 of the Easy Controller software



When a valid input is present, a check “V” appears in the Status box at the GPIO 0:

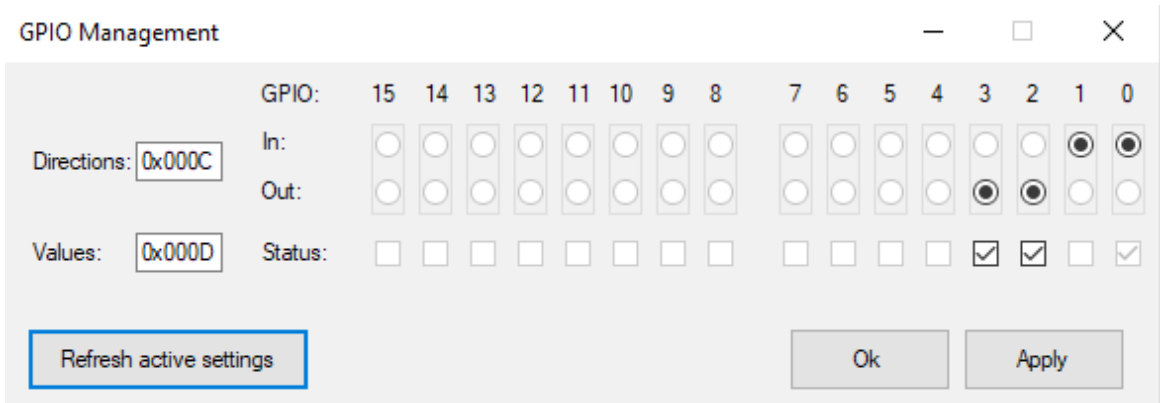

Output signal

The OUTPUT1.1 – OUTPUT1.2 and OUTPUT2.1 – OUTPUT2.2 pins are the terminals of a normally open dry contacts.

By connecting to the CAEN RFID Easy Controller Software, Tools-I/O management section, you can close the contact by removing the check from the Status box related to GPIO 2 and GPIO 3 and then press the Apply button.

OUTPUT1.1 – OUTPUT1.2 correspond to GPIO2 of the Easy Controller software

OUTPUT2.1 – OUTPUT2.2 correspond to GPIO3 of the Easy Controller software

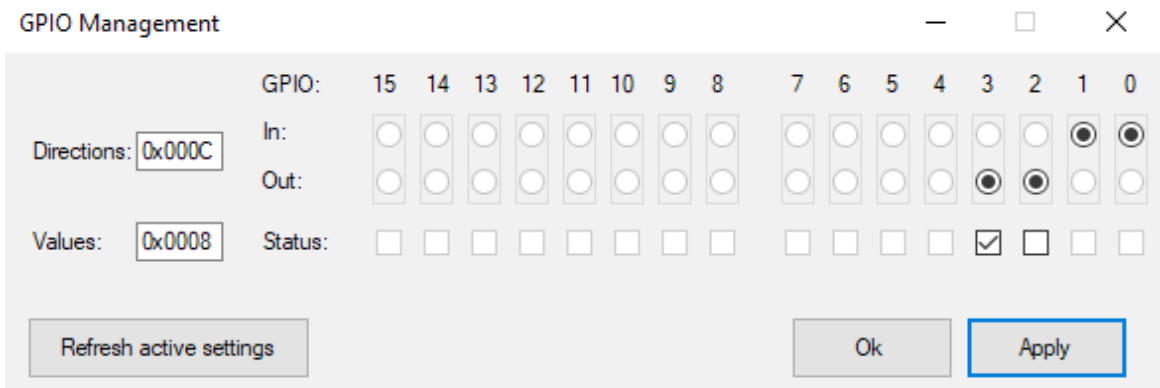

To supply a user U1 to V_INT , make the connection as shown in the drawing below:

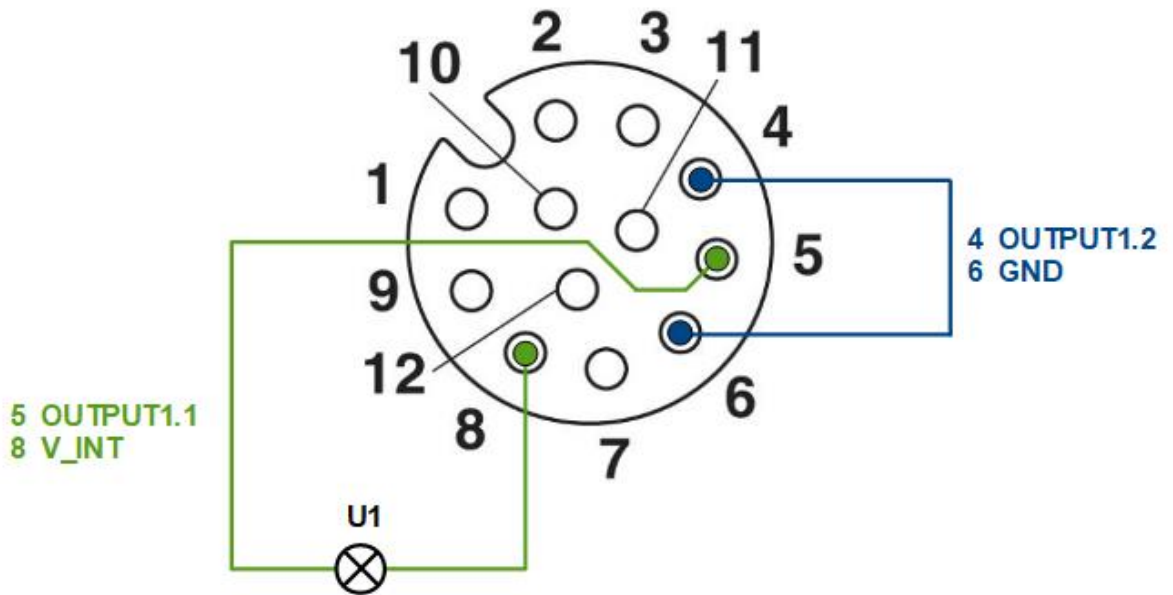

Fig. 3.9: GPIO Output Signal

RS232 Communication

The following figure shows an example of a serial connection between the reader and a PC:

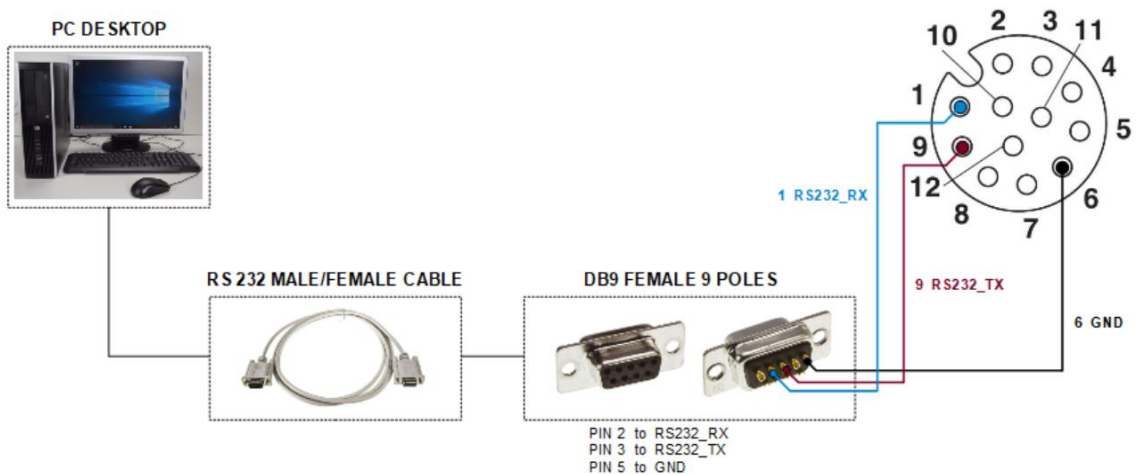

Fig. 3.10: Example of a serial connection between the reader and a PC

If your pc does not have a native RS232 port, it is possible to connect the reader using a USB/RS232 converter, as shown in the following figure. Note that this is the configuration used to execute the upgrade of the reader as indicated in the § *Firmware Upgrade* paragraph page 53.

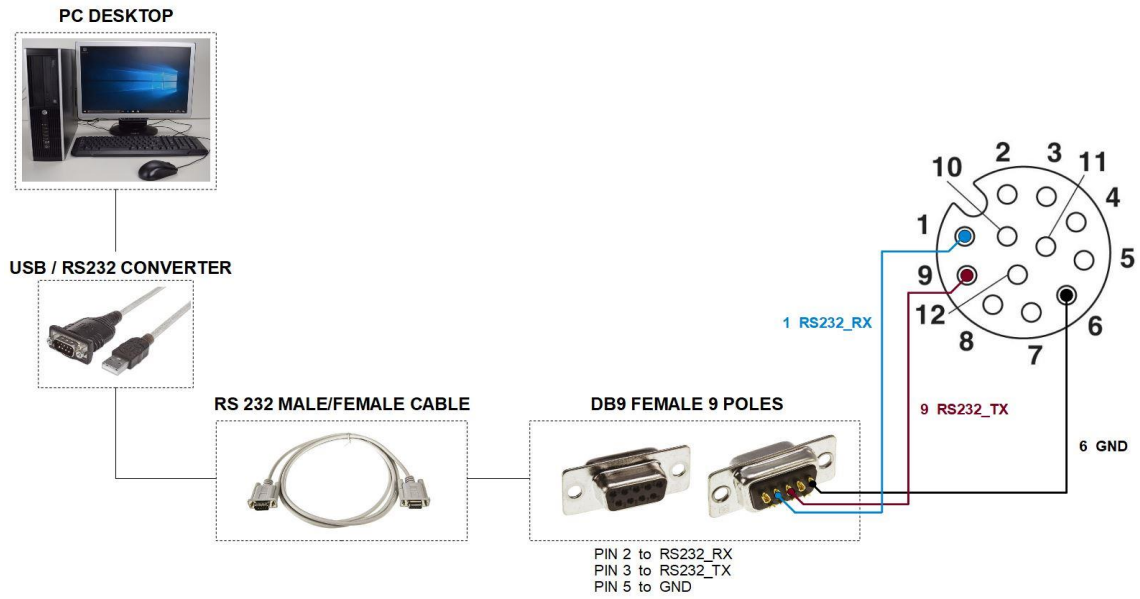

Fig. 3.11: Example of a serial connection between the reader and a PC using a USB/RS232 converter

Antennas

The Proton R4320P reader has 4 antenna ports capable of a 31.5 dBm maximum power enabling to build RAIN RFID portals for logistic.

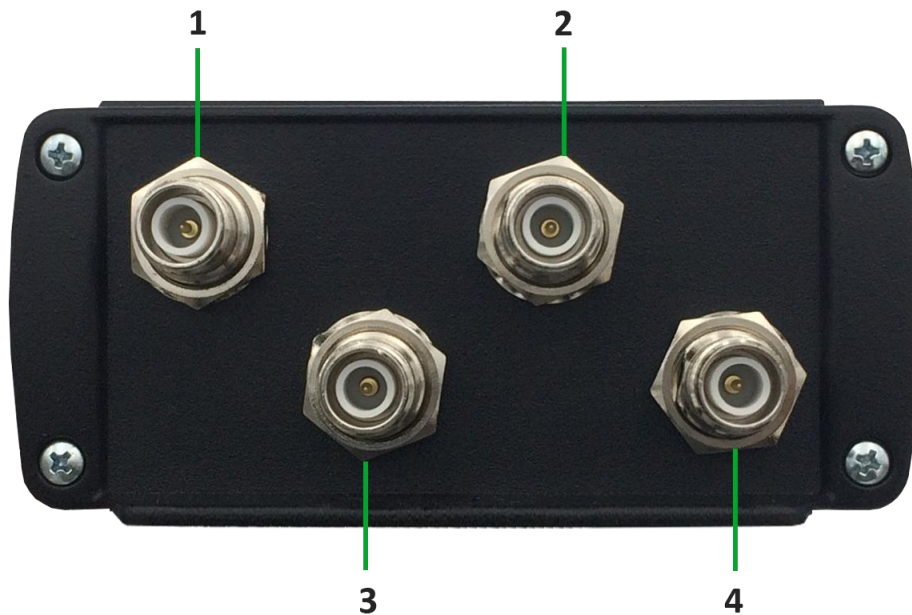

Fig. 3.12: Proton R4320P Antennas

No.	Name	Description
1	ANT 0	50Ω RP-TNC jack connector Antenna 0
2	ANT 2	50Ω RP-TNC jack connector Antenna 2
3	ANT 1	50Ω RP-TNC jack connector Antenna 1
4	ANT 3	50Ω RP-TNC jack connector Antenna 3

Tab. 3.8: Proton R4320P Antennas

In order to achieve the best reading performances, the VSWR of the antenna shall be lower than 1.5:1.



Warning: To guarantee the IP65 degree of the device, the antennas must all be wired. If the connector is free, a protective cap must be applied to guarantee the IP65 degree. The following part number is recommended: TNC Cap for Female Connector - AMPHENOL part number 202101-12.

4 CONFIGURATION USING THE WEB INTERFACE

Introduction

The reader can be configured via web interface.

The Web Interface is accessible only via the Ethernet connection:

1. Connect the Proton to the power supply.
2. Plug an Ethernet cable (not provided) into your computer and connect the other end of the Ethernet cable to the reader. By default, the Proton R4320P is configured with the static IP address 192.168.0.2. If your private network matches the default network configuration of the reader you can connect to it. Otherwise you can either change the network configuration of the reader (see § NETWORK page 26) to connect it to your network or disconnect your PC from your network and connect it to the network of the reader.

By factory default, the Proton web interface is reachable at the following IP address: 192.168.0.2.

To login, type **root** in the Username text box and **root** in the Password textbox. To change the username and password please refer to § SYSTEM page 27.

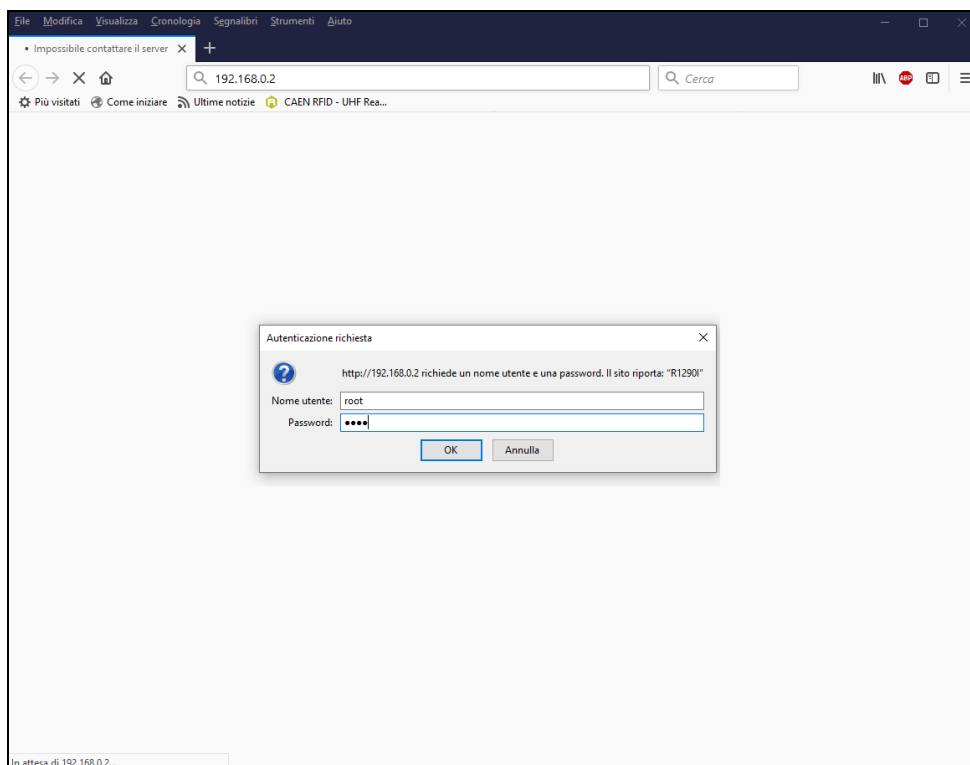

When the connection with the reader is established, the main screen of the web interface is displayed:

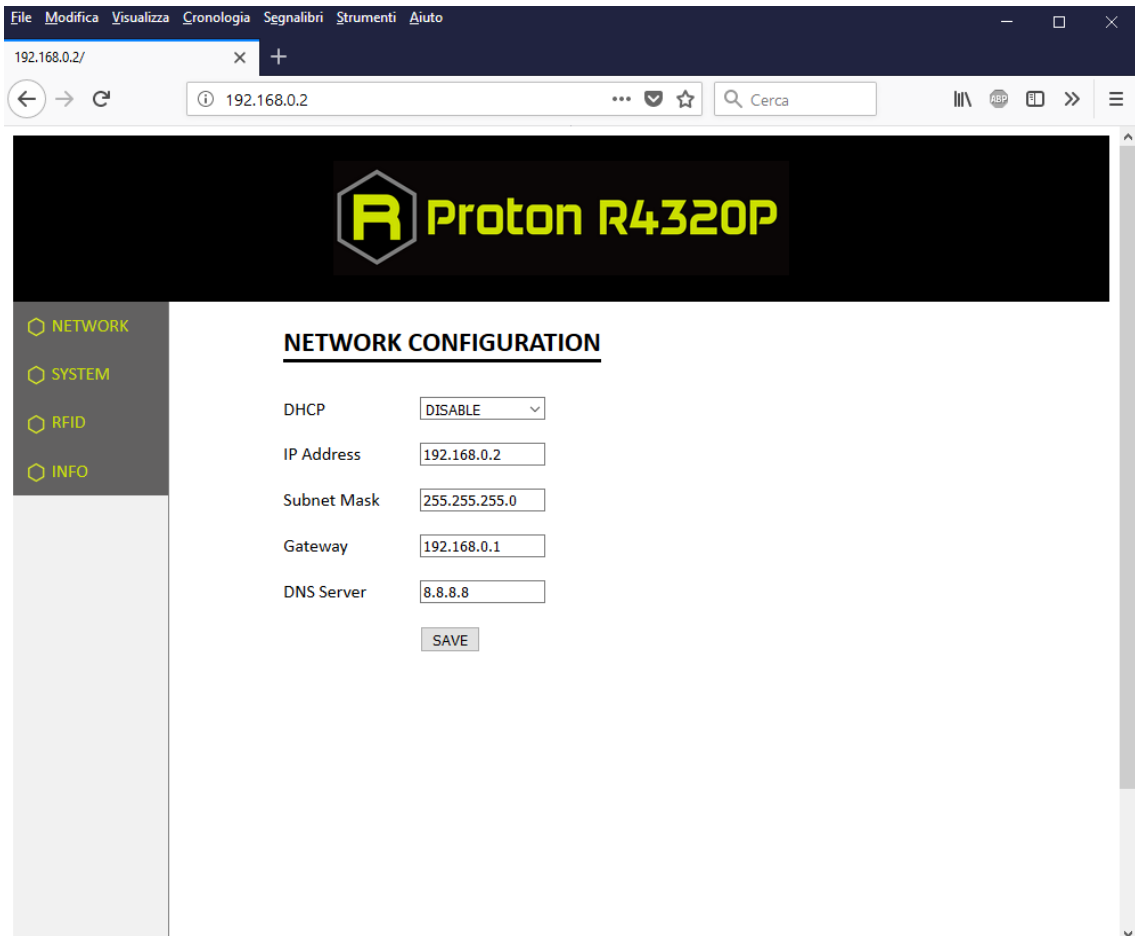
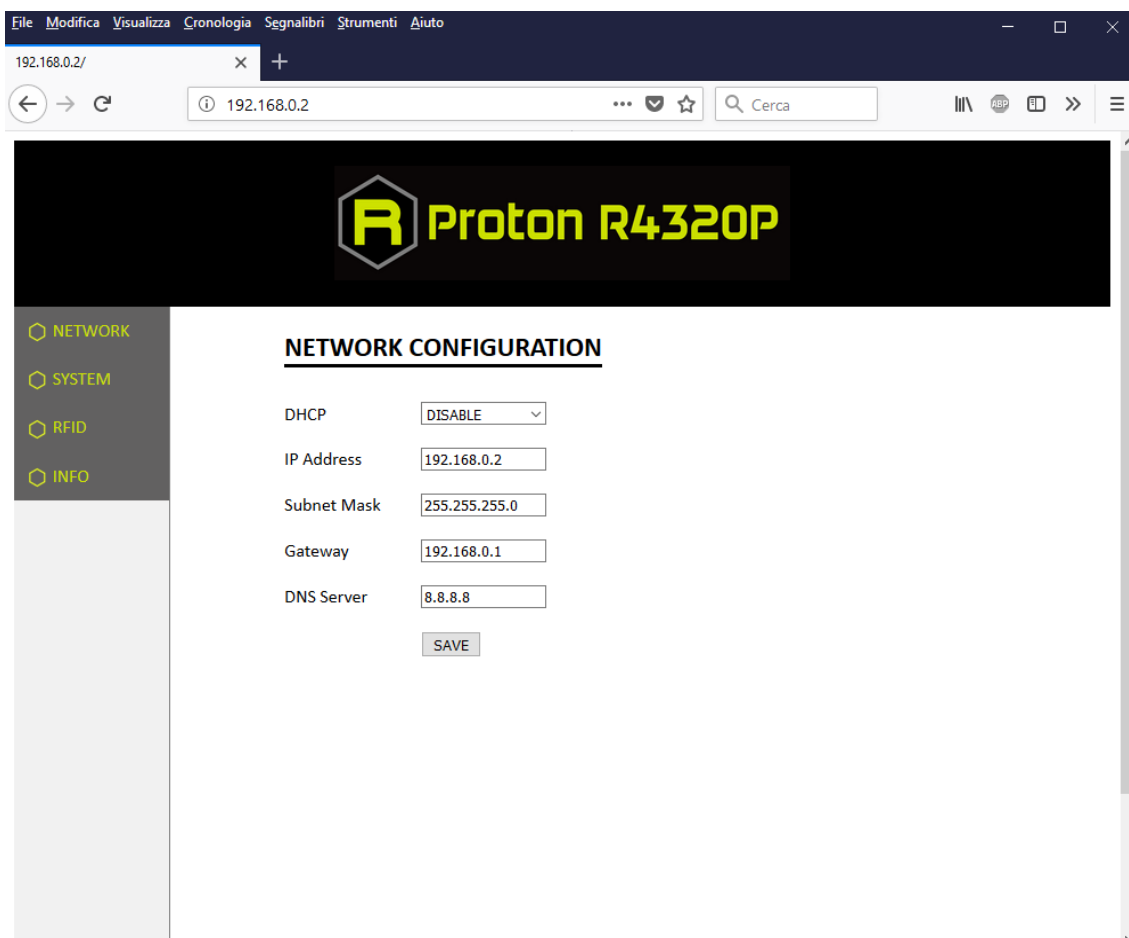

Fig. 4.1: Proton R4320P Web Interface

The Web Interface menu options are the following:

- **NETWORK**
- **SYSTEM**
- **RFID**
- **INFO**

NETWORK



The NETWORK submenu options are the following:

- **DHCP:** Enable/Disable. By default the DHCP is set to *disable*. You can change the default value using the drop-down menu.
- **IP Address:** the reader default IP address is 192.168.0.2. The Proton reader can be connected to a PC using an Ethernet cable; in order to correctly operate with the reader refer to *Ethernet Communication Setup* page 41.
- **Subnet Mask:** the reader default subnet mask is 255.255.255.0.
- **Gateway:** the reader default gateway is 192.168.0.1.
- **DNS Server:** the reader default DNS server is 8.8.8.8.



Warning: To save the changes click on the “*SAVE*” button. Note that all changes made via the web interface are active only after the reader’s reboot. Click on *SYSTEM* option in the Web Interface panel and then click on the “*Reboot*” button. After reboot, the new settings are active.

SYSTEM

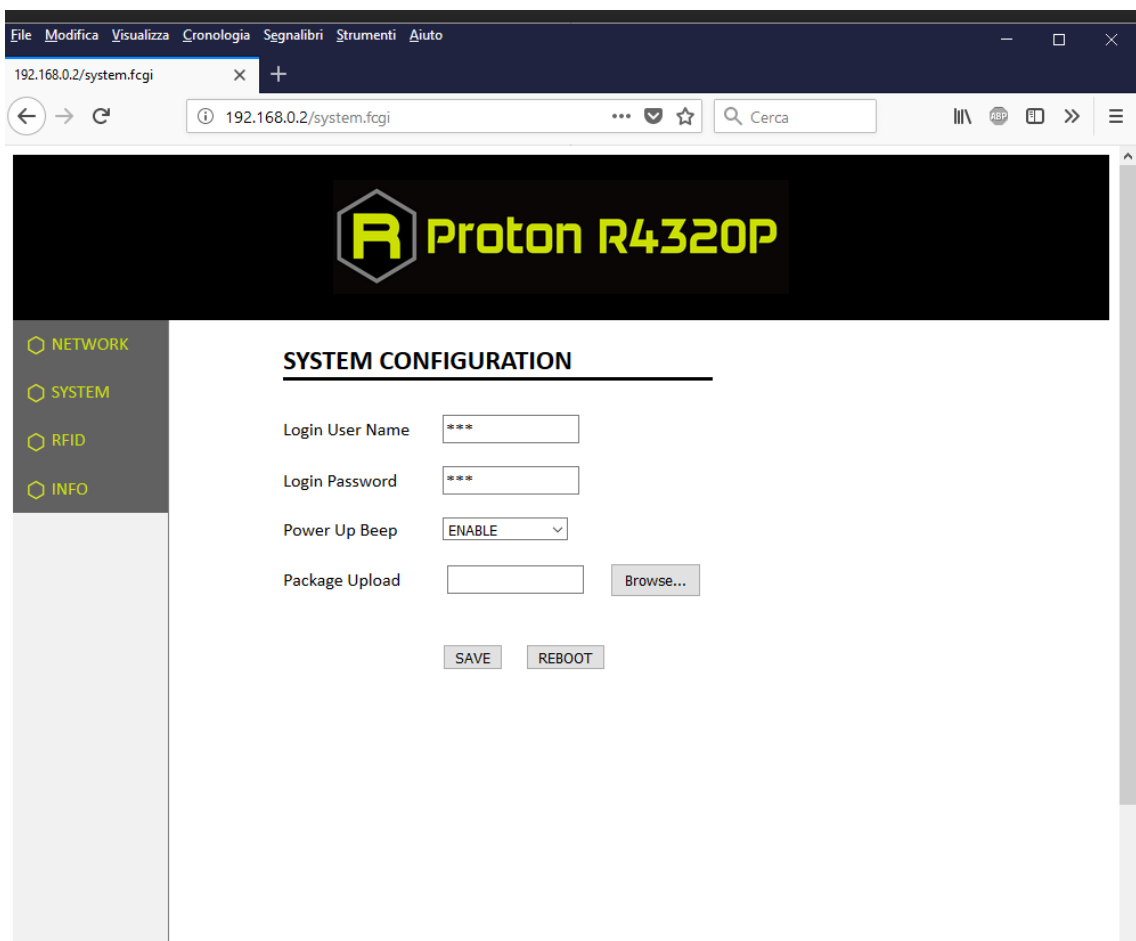

The SYSTEM CONFIGURATION options are the following:

- **Login User Name:** To access the web interface, the default username is “root”. Use this option to change the login username.



Warning: If you forgot your username you must necessarily make a factory reset (see § Firmware Upgrade page 53)

- **Login Password:** To access the web interface, the default password is “root”. Use this option to change the login password.



Warning: If you forgot your password you must necessarily make a factory reset (see § Firmware Upgrade page 53)

- **Power Up Beep:** enable or disable. By default, the *Power Up Beep* is enabled. Through this option you can enable or disable the beep at the power up of the reader.
- **Package Upload:** use this function to upload the script program to be used with the custom profile. Give the package the same name used for the code. Please remember to keep your code as simple as possible; the R4320P reader scripting capability is meant for running inside the reader very simple task (max 3 MB). For more information on the use of the custom profile please refer to § CUSTOM Profile page 51.



Warning: To save the changes click on the “SAVE” button. Note that all changes made via the web interface are active only after the reader’s reboot. Click on the “Reboot” button. After reboot, the new settings are active.

RFID

Use this section in order to set the desired profile and then the related configuration options.

Profile

You can change the profile value using the drop-down menu:

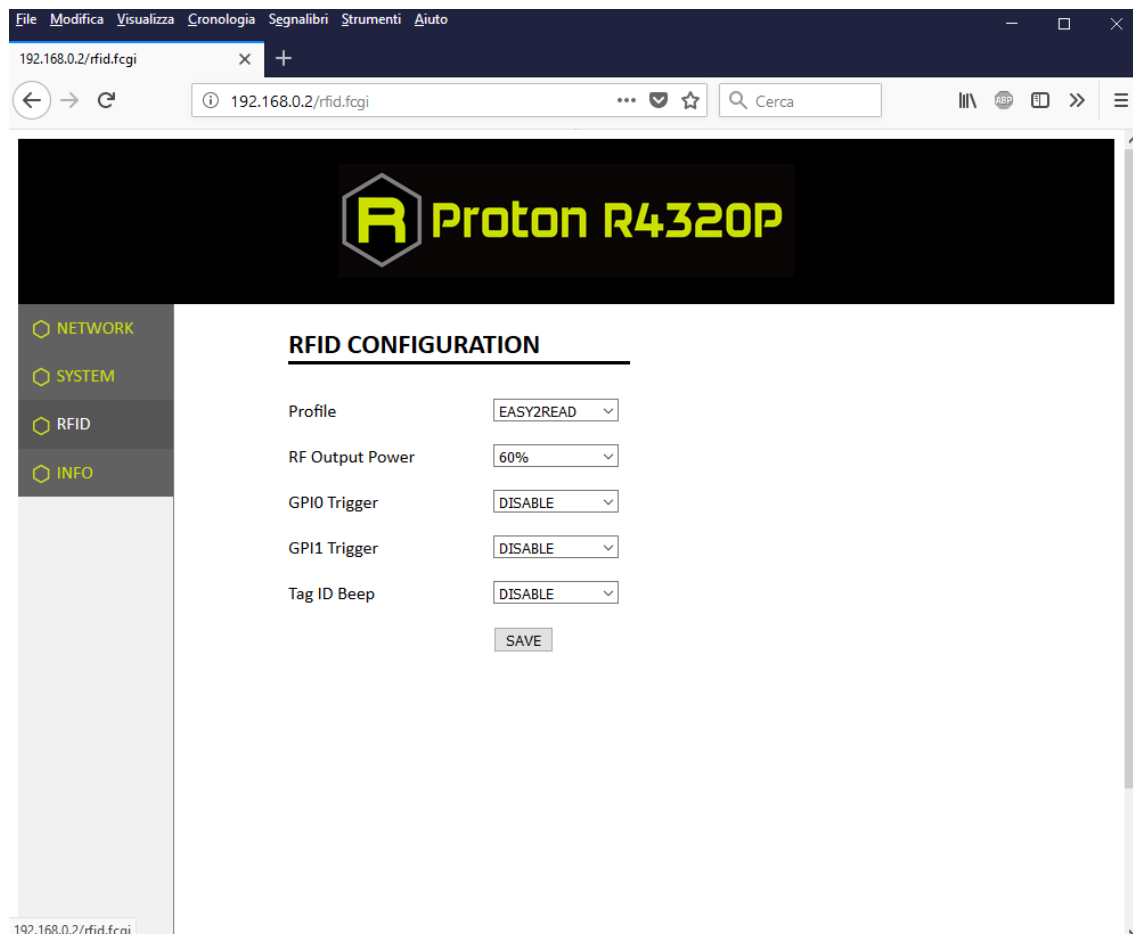

The available profiles are:

- Easy2read (factory default)** is the CAEN RFID easy2read communication protocol that permits to control the reader using the CAEN RFID Easy Controller Application or the SDK (Software Development Kit) library. For details on the use of the easy2read profile please refer to § EASY2READ Profile chapter page 41.
 For details on the easy2read configuration options, refer to § *Easy2read Configuration Options* paragraph page 29.
- HID:** choosing this option you select the keyboard emulation protocol. For details on the use of the HID profile please refer to § *HID Profile* chapter page 49.
 For details on the HID configuration options, refer to § *HID Configuration Options* paragraph page 31.
- Custom:** the use of this profile allows the user to upload his own scripts to the reader. For details on the use of the Custom profile please refer to § *CUSTOM Profile* chapter page 51.
 For details on the Custom configuration options, refer to § *Custom Configuration Options* paragraph page 38.

Easy2read Configuration Options

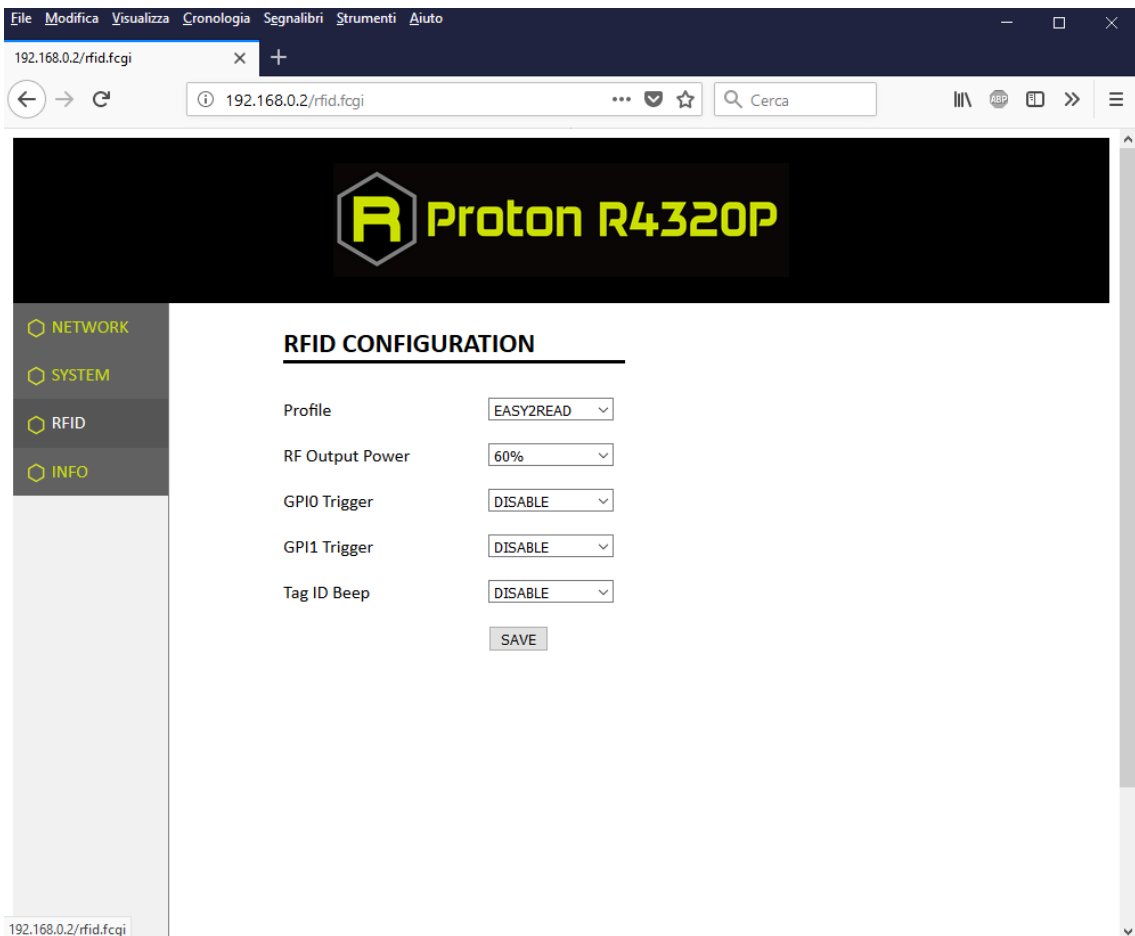

Choosing the easy2read profile, the RFID Configuration submenu options are the following:

- **RF Output Power:** the default RF Power is 60%. The RF Power value at power up is expressed as a percentage value of the maximum RF output power. Through the *RF Output Power* submenu you can set the power level emitted by the reader. You can change the default value using the drop-down menu:
 - 5%
 - 10%
 - 20%
 - 40%
 - 60%
 - 80%
 - 100%

The correspondent values are:

Percentage	Conducted Power ETSI (mW)	Conducted Power FCC (mW)
5%	70	70
10%	140	140
20%	280	280
40%	560	560
60%	840	840
80%	1120	1000 ²
100%	1400	1000 ²

Tab. 4.1: Conducted power

Note that, when the reader is configured in the easy2read profile, to set the power you can also use the CAEN RFID Easy Controller Application or the *SetPower* function of the SDK (Software Development Kit) library.

- **GPIO0 Trigger:** enable or disable. By default, the *GPIO0 Trigger* is disabled. You can change the default value using the drop-down menu. Through this option you can enable/disabled the tag inventory at the change of state of the GPIO0.



Note: In the easy2read profile, in order to enable the tag inventory on GPIO0 trigger, it is necessary to perform a second activation via software:

- **Using the Easy controller Software:** for more details see § *Inventory on GPIO state change* page 47.
- or
- **Using the API:** for more details see the *EventInventoryTag* Method (the *event trigger flag*, bit 5, set to 1) in the *CAEN RFID API Reference Manual* downloadable from [Proton R4320P web page](#), *Documents* section or in the [Manual and Documents](#) web area.

- **GPIO1 Trigger:** enable or disable. By default, the *GPIO1 Trigger* is disabled. You can change the default value using the drop-down menu. Through this option you can enable/disabled the tag inventory at the change of state of the GPIO1.



Note: In the easy2read profile, in order to enable the tag inventory on GPIO1 trigger, it is necessary to perform a second activation via software:

- **Using the Easy controller Software:** for more details see § *Inventory on GPIO state change* page 47.
- or
- **Using the API:** for more details see the *EventInventoryTag* Method (the *event trigger flag*, bit 5, set to 1) in the *CAEN RFID API Reference Manual* downloadable from [Proton R4320P web page](#), *Documents* section or in the [Manual and Documents](#) web area.

- **Tag ID Beep:** enable or disable. By default, the *Tag ID beep* is disabled. You can change the default value using the drop-down menu. If the *Tag ID beep* is enabled, the reader will beep when a tag is detected.



Warning: To save the changes click on the “*SAVE*” button. Note that all changes made via the web interface are active only after the reader’s reboot. Click on *SYSTEM* option in the Web Interface panel and then click on the “*Reboot*” button. After reboot, the new settings are active.

² The reader with the FCC regulation cannot supply more than 1000 mW to the connector. By analogy with the power expressed in the ETSI table, the percentage refers to the full scale of 1400mW, but the percentage of 80% and 100% (that exceed 1000mW) are limited to the maximum of 1000 mW.

HID Configuration Options

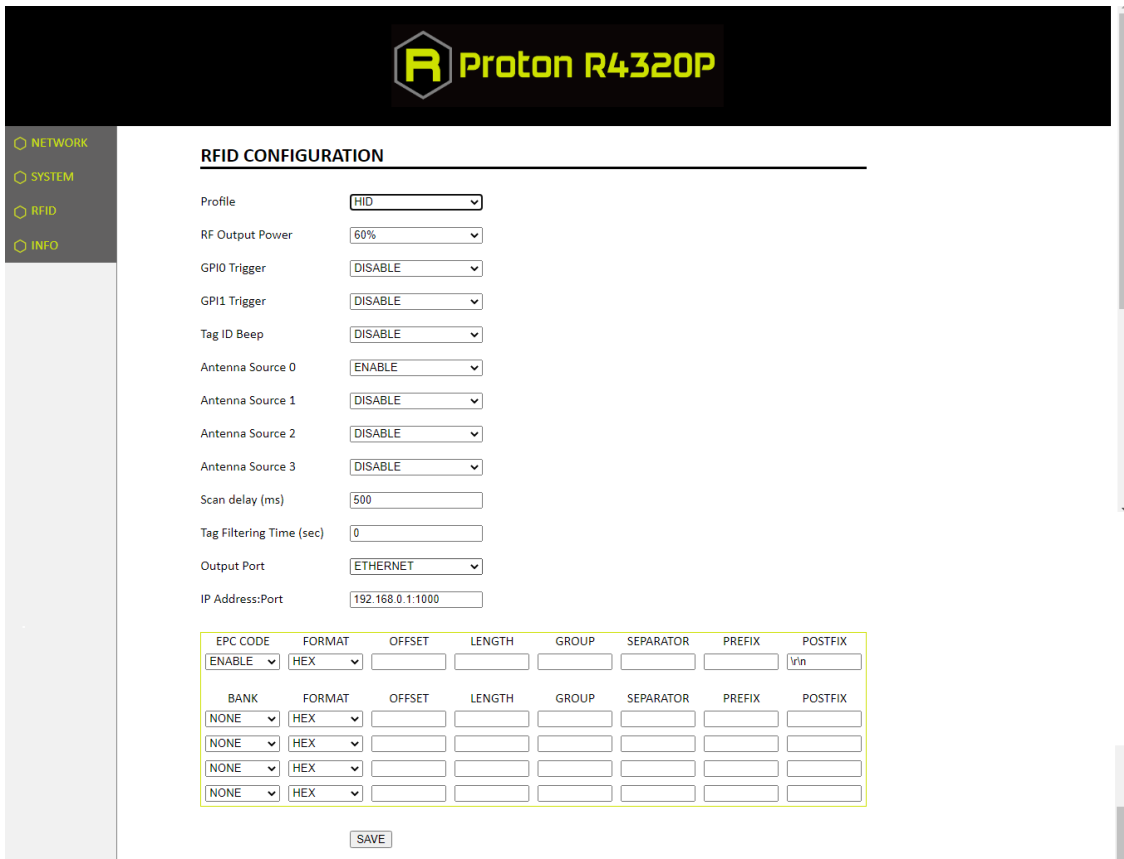

RFID CONFIGURATION

Profile:

RF Output Power:

GPIO Trigger:

GPI1 Trigger:

Tag ID Beep:

Antenna Source 0:

Antenna Source 1:

Antenna Source 2:

Antenna Source 3:

Scan delay (ms):

Tag Filtering Time (sec):

Output Port:

IP Address:Port:

EPC CODE	FORMAT	OFFSET	LENGTH	GROUP	SEPARATOR	PREFIX	POSTFIX
<input type="text" value="ENABLE"/>	<input type="text" value="HEX"/>	<input type="text"/>	<input type="text"/>	<input type="text"/>	<input type="text"/>	<input type="text"/>	<input type="text" value="r/n"/>

BANK	FORMAT	OFFSET	LENGTH	GROUP	SEPARATOR	PREFIX	POSTFIX
<input type="text" value="NONE"/>	<input type="text" value="HEX"/>	<input type="text"/>	<input type="text"/>	<input type="text"/>	<input type="text"/>	<input type="text"/>	<input type="text"/>
<input type="text" value="NONE"/>	<input type="text" value="HEX"/>	<input type="text"/>	<input type="text"/>	<input type="text"/>	<input type="text"/>	<input type="text"/>	<input type="text"/>
<input type="text" value="NONE"/>	<input type="text" value="HEX"/>	<input type="text"/>	<input type="text"/>	<input type="text"/>	<input type="text"/>	<input type="text"/>	<input type="text"/>
<input type="text" value="NONE"/>	<input type="text" value="HEX"/>	<input type="text"/>	<input type="text"/>	<input type="text"/>	<input type="text"/>	<input type="text"/>	<input type="text"/>

The use of the *HID* profile allows the user to select the keyboard emulation protocol.

Choosing the HID profile, the HID Configuration submenu options are the following:

- **RF Output Power:** the default RF Power is 60%. The RF Power value at power up is expressed as a percentage value of the maximum RF output power. Through the *RF Output Power* submenu you can set the power level emitted by the reader. You can change the default value using the drop-down menu:
 - 5%
 - 10%
 - 20%
 - 40%
 - 60%
 - 80%
 - 100%

The correspondent values are:

Percentage	Conducted Power	Conducted Power
	ETSI (mW)	FCC (mW)
5%	70	70
10%	140	140
20%	280	280
40%	560	560
60%	840	840
80%	1120	1000 ³
100%	1400	1000 ³

Tab. 4.2: Conducted power

- GPIO0 Trigger:** Through this option you can enable/disable the tag inventory at the change of state of the GPIO0. By default, the GPIO0 Trigger is disabled. You can change the default value using the drop-down menu:
 - **Enable (one shot):** enables the tag inventory each time the GPIO0 toggles from *Low* to *High*
 - **Enable (start/stop):** starts the tag inventory when the GPIO0 toggles to *High* and repeats the inventory until the GPIO0 returns to *Low* (stop)
- GPIO1 Trigger:** Through this option you can enable/disable the tag inventory at the change of state of the GPIO1. By default, the GPIO1 Trigger is disabled. You can change the default value using the drop-down menu:
 - **Enable (one shot):** enables the tag inventory each time the GPIO1 toggles from *Low* to *High*
 - **Enable (start/stop):** starts the tag inventory when the GPIO1 toggles to *High* and repeats the inventory until the GPIO0 returns to *Low* (stop)
- Tag ID Beep:** enable or disable. By default, the *Tag ID beep* is disabled. You can change the default value using the drop-down menu. If the *Tag ID beep* is enabled, the reader will beep when detects 1 tag during the inventory.
- Antenna Source 0:** enable or disable. By default, the *Antenna Source 0* is enabled. You can change the default value using the drop-down menu. If the *Antenna Source 0* is enabled, the reader performs the inventory using this antenna.
- Antenna Source 1:** enable or disable. By default, the *Antenna Source 1* is disabled. You can change the default value using the drop-down menu. If the *Antenna Source 1* is enabled, the reader performs the inventory using this antenna.
- Antenna Source 2:** enable or disable. By default, the *Antenna Source 2* is disabled. You can change the default value using the drop-down menu. If the *Antenna Source 2* is enabled, the reader performs the inventory using this antenna.
- Antenna Source 3:** enable or disable. By default, the *Antenna Source 3* is disabled. You can change the default value using the drop-down menu. If the *Antenna Source 3* is enabled, the reader performs the inventory using this antenna.
- Scan Delay (ms):** Scan Delay is an editable field and the value is expressed in ms. By default, the scan delay is 500 ms. The scan delay is the time between two inventories (in case of continuous inventory mode with no triggers enabled).

Note that if the GPIO0 trigger or GPIO1 trigger are enabled, the scan delay is ignored.
- Tag Filtering Time (sec):** this option is useful to avoid the retransmission of the same tag for a time equal to the tag filtering time. By default, the *Tag Filtering Time* is set to 0 and the tag is transmitted at each reading. For example, if *Tag Filtering Time* is set to 5s and a tag is read, it is transmitted the first time then it will be retransmitted after 5 seconds if read again.
- Output Port:** determines the format and transmission of data of the read tags. By default, the *Output Port* is set to *Ethernet*. You can change the default value using the drop-down menu:
 - **RS232:** choosing this option, it is requested to insert the *Baud Rate*, see the example below:

³ The reader with the FCC regulation cannot supply more than 1000 mW to the connector. By analogy with the power expressed in the ETSI table, the percentage refers to the full scale of 1400mW, but the percentage of 80% and 100% (that exceed 1000mW) are limited to the maximum of 1000 mW.

Scan delay (ms)

Tag Filtering Time (sec)

Output Port

Baud Rate

EPC CODE	FORMAT	OFFSET	LENGTH	GROUP	SEPARATOR	PREFIX	POSTFIX
ENABLE	HEX	<input type="text"/>	<input type="text"/>	<input type="text"/>	<input type="text"/>	<input type="text"/>	\r\n
BANK	FORMAT	OFFSET	LENGTH	GROUP	SEPARATOR	PREFIX	POSTFIX
NONE	HEX	<input type="text"/>	<input type="text"/>	<input type="text"/>	<input type="text"/>	<input type="text"/>	<input type="text"/>
NONE	HEX	<input type="text"/>	<input type="text"/>	<input type="text"/>	<input type="text"/>	<input type="text"/>	<input type="text"/>
NONE	HEX	<input type="text"/>	<input type="text"/>	<input type="text"/>	<input type="text"/>	<input type="text"/>	<input type="text"/>
NONE	HEX	<input type="text"/>	<input type="text"/>	<input type="text"/>	<input type="text"/>	<input type="text"/>	<input type="text"/>

(press SAVE then REBOOT to enable the UPDATE button)

- **ETHERNET:** choosing this option, it is requested to insert the *IP Address:Port*, see the example below:

Scan delay (ms)

Tag Filtering Time (sec)

Output Port

IP Address:Port

EPC CODE	FORMAT	OFFSET	LENGTH	GROUP	SEPARATOR	PREFIX	POSTFIX
ENABLE	HEX	<input type="text"/>	<input type="text"/>	<input type="text"/>	<input type="text"/>	<input type="text"/>	\r\n
BANK	FORMAT	OFFSET	LENGTH	GROUP	SEPARATOR	PREFIX	POSTFIX
NONE	HEX	<input type="text"/>	<input type="text"/>	<input type="text"/>	<input type="text"/>	<input type="text"/>	<input type="text"/>
NONE	HEX	<input type="text"/>	<input type="text"/>	<input type="text"/>	<input type="text"/>	<input type="text"/>	<input type="text"/>
NONE	HEX	<input type="text"/>	<input type="text"/>	<input type="text"/>	<input type="text"/>	<input type="text"/>	<input type="text"/>
NONE	HEX	<input type="text"/>	<input type="text"/>	<input type="text"/>	<input type="text"/>	<input type="text"/>	<input type="text"/>

(press SAVE then REBOOT to enable the UPDATE button)

EPC code parameters

Using the table below you can customize the text of the code displayed on the screen:

EPC CODE	FORMAT	OFFSET	LENGTH	GROUP	SEPARATOR	PREFIX	POSTFIX
ENABLE	HEX						\r\n
BANK	FORMAT	OFFSET	LENGTH	GROUP	SEPARATOR	PREFIX	POSTFIX
NONE	HEX						
NONE	HEX						
NONE	HEX						
NONE	HEX						

SAVE

Tab. 4.3: EPC Code parameters

- **EPC Code:** enable or disable. By default, the *EPC Code* is enabled and the EPC code is returned in the message sent by the reader. You can change the default value using the drop-down menu.
- **FORMAT:** In the HID profile you can set different EPC formats:
 - HEX: The EPC code is represented as a hexadecimal number. For example, an EPC Code of 96 bits long corresponds to 24 hexadecimal digits ($96/4=24$).
 - ASCII: The EPC code is interpreted as 8 bits at a time, each byte being represented as ASCII character. For example, an EPC Code of 96 bits corresponds to a string of 12 ASCII characters ($96/8 = 12$).

By default the EPC HID format is set to "HEX". You can change the default value using the drop-down menu.

- **OFFSET:** optional. The "offset" indicates after how many characters start counting the "length" value. By default the offset string is empty.
- **LENGTH:** number of characters of the EPC code to be displayed counting from the "offset". If not set, all the EPC code is displayed. By default the length string is empty.
- **GROUP:** the EPC code characters are grouped according to the value set in "group". By default the group string is empty.
- **SEPARATOR:** separator used to distinguish groups. By default the separator string is empty.
- **PREFIX:** The PREFIX option permits to specify a string to add before the EPC when a tag is read.

The following list shows the accepted characters for the prefix:

'a', 'b', 'c', 'd', 'e', 'f', 'g', 'h', 'i', 'j', 'k', 'l', 'm', 'n', 'o', 'p', 'q', 'r', 's', 't', 'u', 'v', 'w', 'x', 'y', 'z', 'A', 'B', 'C', 'D', 'E', 'F', 'G', 'H', 'I', 'J', 'K', 'L', 'M', 'N', 'O', 'P', 'Q', 'R', 'S', 'T', 'U', 'V', 'W', 'X', 'Y', 'Z', '0', '1', '2', '3', '4', '5', '6', '7', '8', '9', '{', '|', '}', '!', '"', '#', '\$', '(', ')', '*', '+', ',', '-', '.', ':', ';', '=', '?', '@', '[', ']', '^', '_', '\'

By default the prefix string is empty.



Warning: if you are using a qwerty keyboard, pay attention that it is a **standard** qwerty keyboard because if not the conversion of symbols could create display problems.

- **POSTFIX:** The POSTFIX option permits to specify a string to add after the EPC when a tag is read.

The following list shows the accepted characters for the postfix:

'a', 'b', 'c', 'd', 'e', 'f', 'g', 'h', 'i', 'j', 'k', 'l', 'm', 'n', 'o', 'p', 'q', 'r', 's', 't', 'u', 'v', 'w', 'x', 'y', 'z', 'A', 'B', 'C', 'D', 'E', 'F', 'G', 'H', 'I', 'J', 'K', 'L', 'M', 'N', 'O', 'P', 'Q', 'R', 'S', 'T', 'U', 'V', 'W', 'X', 'Y', 'Z', '0', '1', '2', '3', '4', '5', '6', '7', '8', '9', '{', '|', '}', '!', '"', '#', '\$', '(', ')', '*', '+', ',', '-', '.', ':', ';', '=', '?', '@', '[', ']', '^', '_', '\'

By default the postfix string is \r\n (see the following table *Tab. 4.4: Escape Sequences supported* page 35).

 **Warning:** if you are using a qwerty keyboard, pay attention that it is a **standard** qwerty keyboard because if not the conversion of symbols could create display problems.

Escape Sequences	Description
\n	Newline (Line Feed)
\r	Carriage Return
\t	Horizontal Tab
\v	Vertical Tab
\\	Backslash

Tab. 4.4: Escape Sequences supported

Using the second part of the *Tab. 4.3: EPC Code parameters* page 34, the same parameters (Format, Offset, Length, Group, Separator, Prefix, Postfix) can be set for individual memory banks (RESERVED, EPC, TID and USER).

Warning: To activate the HID profile click on the “*SAVE*” button. Note that all changes made via the web interface are active only after the reader’s reboot. Click on *SYSTEM* option in the Web Interface panel and then click on the “Reboot” button. After reboot, the new settings are active and the “*UPDATE*” button is enabled:



EPC CODE	FORMAT	OFFSET	LENGTH	GROUP	SEPARATOR	PREFIX	POSTFIX
ENABLE	HEX						\n
BANK	FORMAT	OFFSET	LENGTH	GROUP	SEPARATOR	PREFIX	POSTFIX
NONE	HEX						
NONE	HEX						
NONE	HEX						
NONE	HEX						

(press **SAVE** then **REBOOT** to enable the **UPDATE** button)





EPC CODE	FORMAT	OFFSET	LENGTH	GROUP	SEPARATOR	PREFIX	POSTFIX
ENABLE	HEX						\n
BANK	FORMAT	OFFSET	LENGTH	GROUP	SEPARATOR	PREFIX	POSTFIX
NONE	HEX						
NONE	HEX						
NONE	HEX						
NONE	HEX						

Warning: Once the HID profile has been activated, it is possible to carry out tests by changing values to the various HID options and clicking only on the “UPDATE” button to make the changes immediately active:



EPC CODE	FORMAT	OFFSET	LENGTH	GROUP	SEPARATOR	PREFIX	POSTFIX
ENABLE	HEX					{"epc:"	"}\r\n

BANK	FORMAT	OFFSET	LENGTH	GROUP	SEPARATOR	PREFIX	POSTFIX
NONE	HEX						
NONE	HEX						
NONE	HEX						
NONE	HEX						

UPDATE

SAVE

Warning: To return to the last saved configuration, just click on SYSTEM option in the Web Interface panel and then click on the "Reboot" button.

Otherwise, to save the new settings, click on the “SAVE” button. Then click on SYSTEM option in the Web Interface panel and click on the “Reboot” button. After reboot, the new settings are active.



EPC CODE	FORMAT	OFFSET	LENGTH	GROUP	SEPARATOR	PREFIX	POSTFIX
ENABLE	HEX						\r\n

BANK	FORMAT	OFFSET	LENGTH	GROUP	SEPARATOR	PREFIX	POSTFIX
NONE	HEX						
NONE	HEX						
NONE	HEX						
NONE	HEX						

UPDATE

SAVE

EXAMPLES

Consider the following EPC MEMORY CONTENT (RAW):

0x41 0x42 0x43 0x44 0x45 0x46 0x47 0x48 0x49 0x4A 0x4B 0x4C

HEX FORMAT: 4142434445464748494A4B4C

OFFSET	LENGTH	GROUP	SEPARATOR	PREFIX	POSTFIX
1	6	1	-		.

Result:

1-4-2-4-3-4.

OFFSET	LENGTH	GROUP	SEPARATOR	PREFIX	POSTFIX
3	14	2	:	00	

Result:

0024:34:44:54:64:74:84

OFFSET	LENGTH	GROUP	SEPARATOR	PREFIX	POSTFIX
4	20			CAEN	-

Result:

CAEN434445464748494A4B4C-

ASCII FORMAT: ABCDEFGHIJKL

OFFSET	LENGTH	GROUP	SEPARATOR	PREFIX	POSTFIX
1	6	1	-	-	

Result:

-B-C-D-E-F-G

OFFSET	LENGTH	GROUP	SEPARATOR	PREFIX	POSTFIX
3	6	2	:	-	-

Result:

-DE:FG:HI-

OFFSET	LENGTH	GROUP	SEPARATOR	PREFIX	POSTFIX
				Tag	CAEN

Result:

TagABCDEFGHIJKLCAEN

Custom Configuration Options

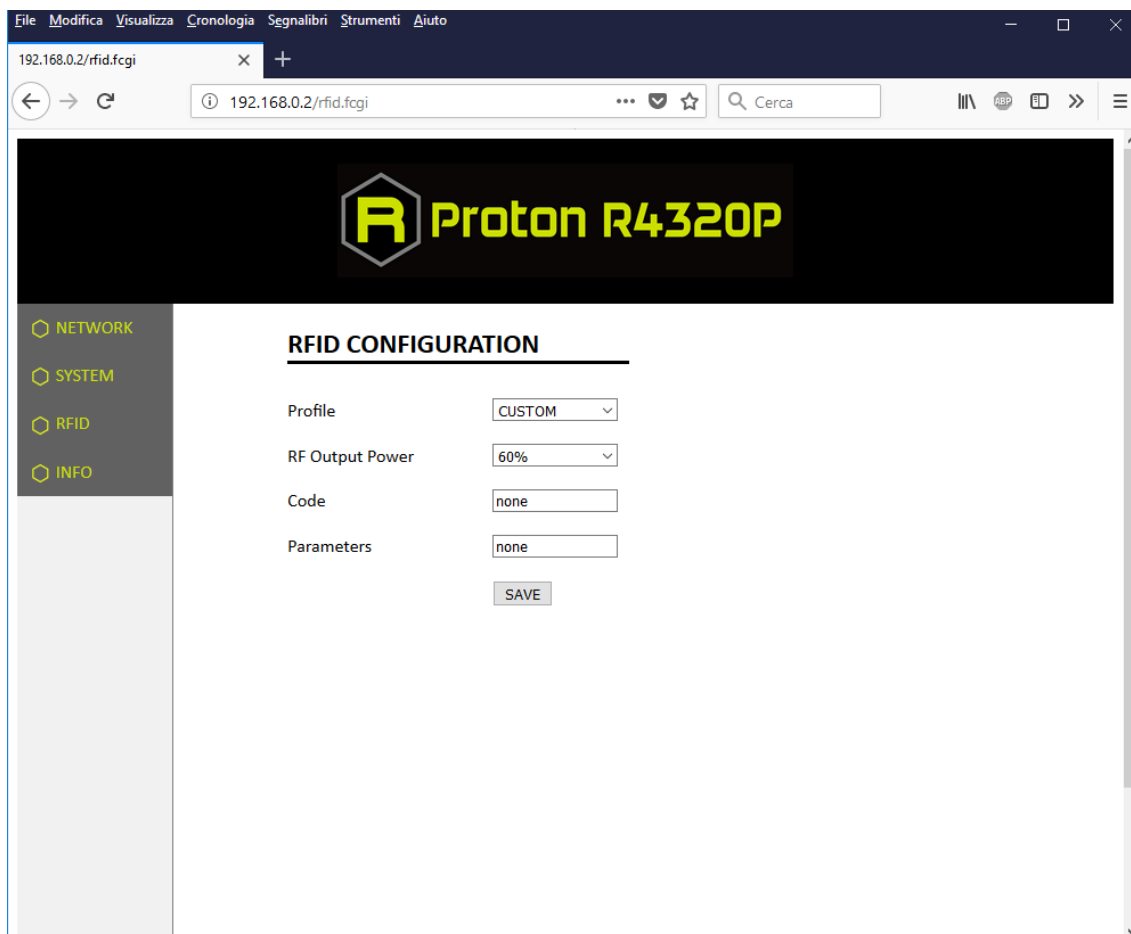

The use of the *Custom* profile allows the user to upload his own scripts to the reader.

Choosing the Custom profile, the RFID Configuration submenu options are the following:

- **RF Output Power:** the default RF Power is 60%. The RF Power value at power up is expressed as a percentage value of the maximum RF output power. Through the *RF Output Power* submenu you can set the power level emitted by the reader. You can change the default value using the drop-down menu:
 - 5%
 - 10%
 - 20%
 - 40%
 - 60%
 - 80%
 - 100%

The correspondent values are:

Percentage	Conducted Power ETSI (mW)	Conducted Power FCC (mW)
5%	70	70
10%	140	140
20%	280	280
40%	560	560
60%	840	840
80%	1120	1000 ⁴
100%	1400	1000 ³

Tab. 4.5: Conducted power

- **Code:** alphanumeric characters. The “code” is the name assigned by the user to the custom program. When the reader is turned on, if the profile is set to custom, among all the programs loaded by the user, the reader starts the custom program named “code”.
- **Parameters:** alphanumeric characters. This string can be used to assign values to the parameters defined by the user in the custom program (e.g. Q=8; n=6; cycles=20, etc...).



Warning: To save the changes click on the “SAVE” button. Note that all changes made via the web interface are active only after the reader’s reboot. Click on *SYSTEM* option in the Web Interface panel and then click on the “Reboot” button. After reboot, the new settings are active un.

⁴ The reader with the FCC regulation cannot supply more than 1000 mW to the connector. By analogy with the power expressed in the ETSI table, the percentage refers to the full scale of 1400mW, but the percentage of 80% and 100% (that exceed 1000mW) are limited to the maximum of 1000 mW.

INFO

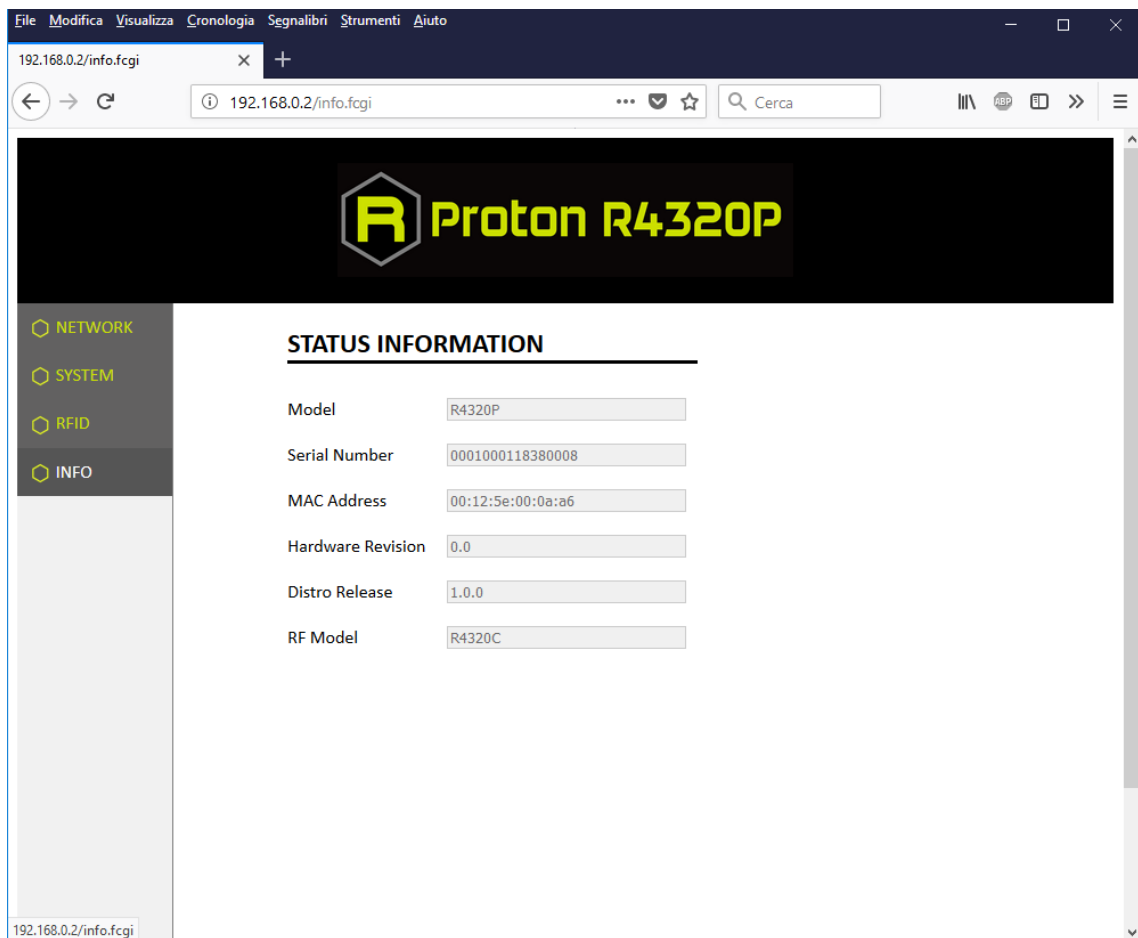

The INFO submenu options are the following:

- **Model:** the model name (e.g. R4320P)
- **Serial Number:** the reader serial number (16 numbers)
- **MAC Address:** the reader MAC address
- **Hardware Revision:** the hardware revision of the reader
- **Distro Release:** Distribution firmware release
- **RF Model:** the internal RF module model, R4320C

5 EASY2READ PROFILE

Introduction

By default, the reader profile is set to easy2read. With the *easy2read* profile active you will use the CAEN RFID easy2read communication protocol. Select this option in order to control the reader using the [CAEN RFID Easy Controller Application](#) or the [SDK \(Software Development Kit\)](#) library.

To configure the reader when using the easy2read profile please refer to the § *Easy2read Configuration Options* paragraph page 29.



Warning: By default the reader is in the easy2read profile.

If your reader is in the **HID** or **CUSTOM** profile active, in order to set the EASY2READ profile, please refer to § *Profile* paragraph page 28.

The Proton reader can be connected to a PC using an Ethernet cable or the serial port.

Connecting using the Ethernet port

Ethernet Communication Setup

The Proton reader can be connected to a PC using an Ethernet cable. In order to correctly operate with the reader follow the steps above:

1. Connect the Proton to the power supply, the power LED will turn on, wait about 30 seconds until you hear a beep, wait 10 seconds again and the reader is ready to work with the easy2read profile active.
2. Plug an Ethernet cable (not provided, see § *Ordering Options* page 9) into your computer and connect the other end of the Ethernet cable to the reader. By default, the Proton reader is configured with the static IP address 192.168.0.2. If your private network matches the default network configuration of the reader you can connect to it. Otherwise you can either change the network configuration of the reader (see § *NETWORK* page 26) to connect it to your network or disconnect your PC from your network and connect it to the network of the reader.
3. Connect the antenna cable to Ant-0 (see § *Fig. 3.12: Proton R4320P Antennas* page 22) of the reader.

Now you can use the [CAEN RFID Easy Controller](#) Application to control the reader.

Easy Controller

Follow these steps to connect the Proton using the *Easy Controller* application for Windows:

1. Download the latest version of the Easy Controller software from the [Proton R4320P web page](#), Downloads section and install it.
2. Launch the *Easy Controller* application:

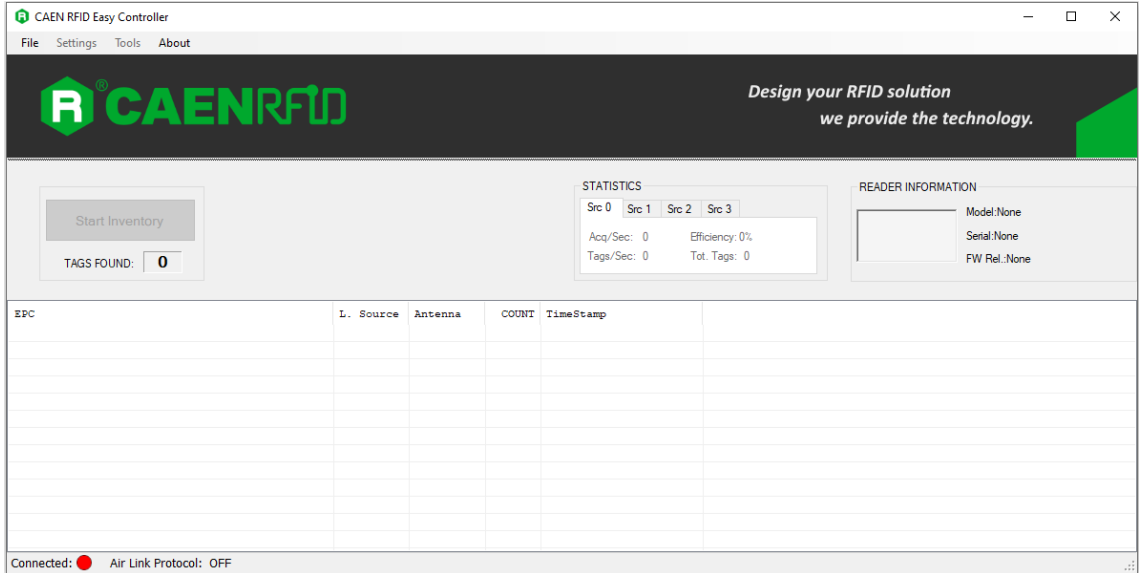

3. On the main screen click on *File* → *Connect*. A Connection windows will open. Select the *Connection Type* (TCP/IP Connection) and type the Proton IP address into the *TCP/IP Address* box (default value is 192.168.0.2). Then click on *Connect*:

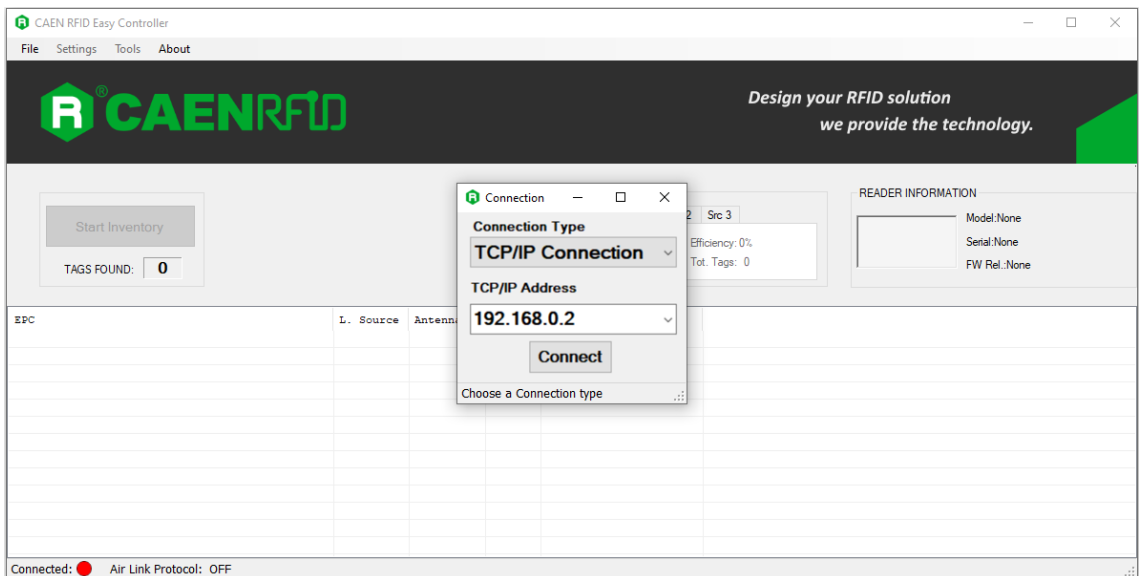

- To verify if the connection with the reader has been established, check the green dot on the bottom left side of the sidebar. Into the *READER INFORMATION* box you can find information on reader model, serial number and firmware release:

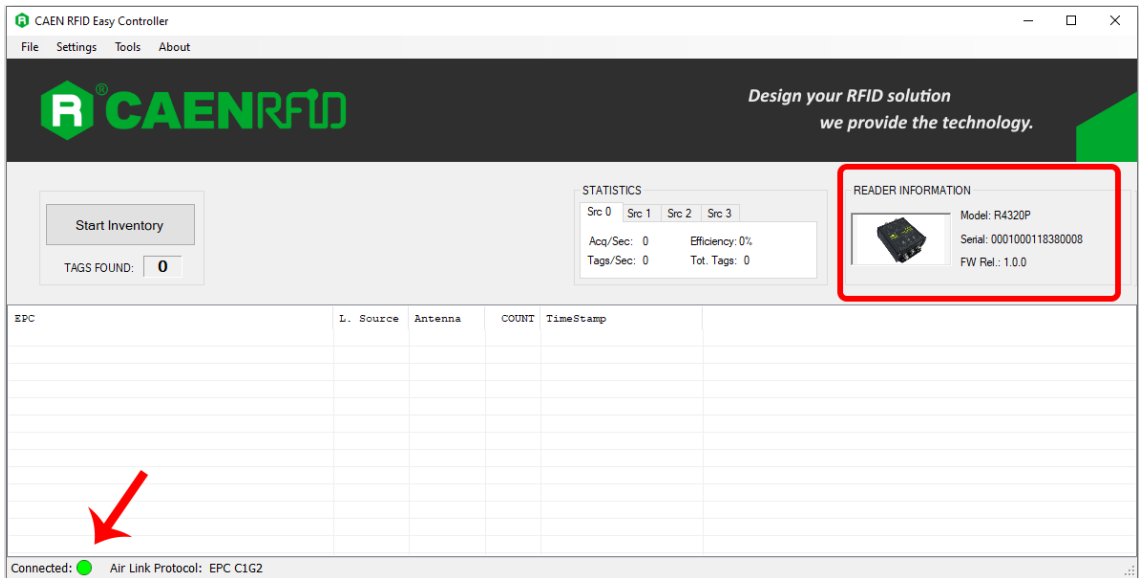

- Place a tag on the read range of the reader, click on *start inventory* and see the tag information displayed on the main window:

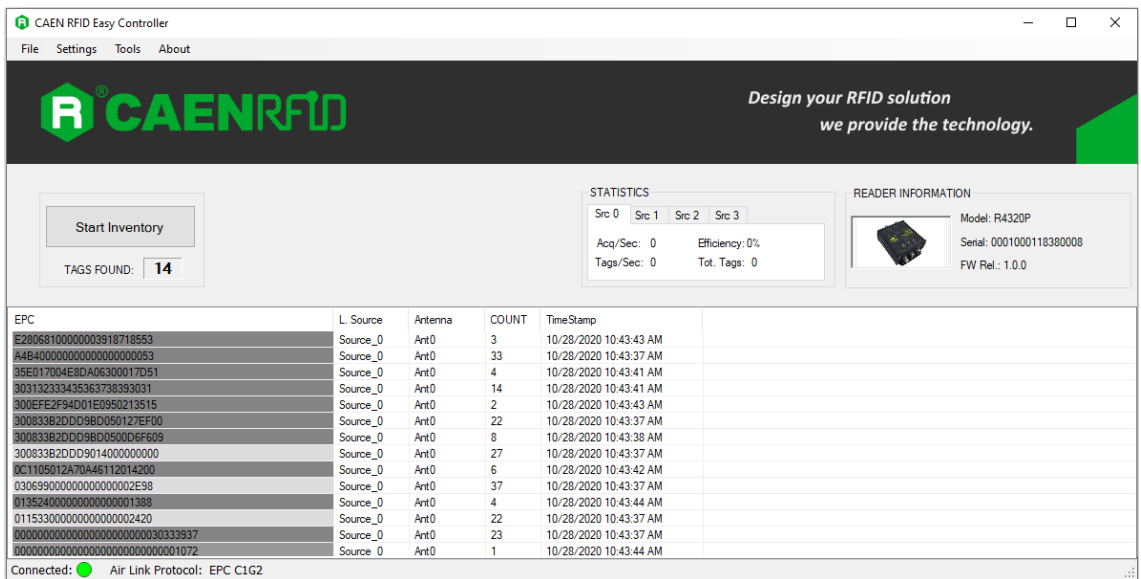

For more info on the use of the *Easy Controller*, please refer to the *CAEN RFID Easy Controller Software Technical Information Manual*, you can download it from the [Proton R4320P web page](#), *Downloads* section or in the [Manual and Documents](#) web area.

Connecting using the serial port

Serial Communication Setup

1. Connect the Proton to the power supply, the power LED will turn on, wait about 30 seconds until you hear a beep, wait 10 seconds again and the reader is ready to work with the easy2read profile active.
2. Connect the Proton to the I/O-Serial cable (not provided). Make the connections as indicated in the paragraph *RS232 Communication* page 21 (example of serial connection between the reader and a PC).
3. Connect the antenna cable to Ant-0 (see § Fig. 3.12: *Proton R4320P Antennas* page 22) of the reader.
4. If you use a native COM PORT of the PC, connect to the COM assigned by the operating system.

Otherwise if you use a USB-SERIAL converter go to *Control Panel* → *Hardware and Sound* → *Devices and Printers*. Look at the COM port number assigned to the USB/serial converter.

Easy Controller

Follow these steps to connect the Proton using the Easy Controller application for Windows:

1. Download the latest version of the Easy Controller software from the [Proton R4320P web page](#), *Downloads* section and install it.
2. Launch the Easy Controller application:

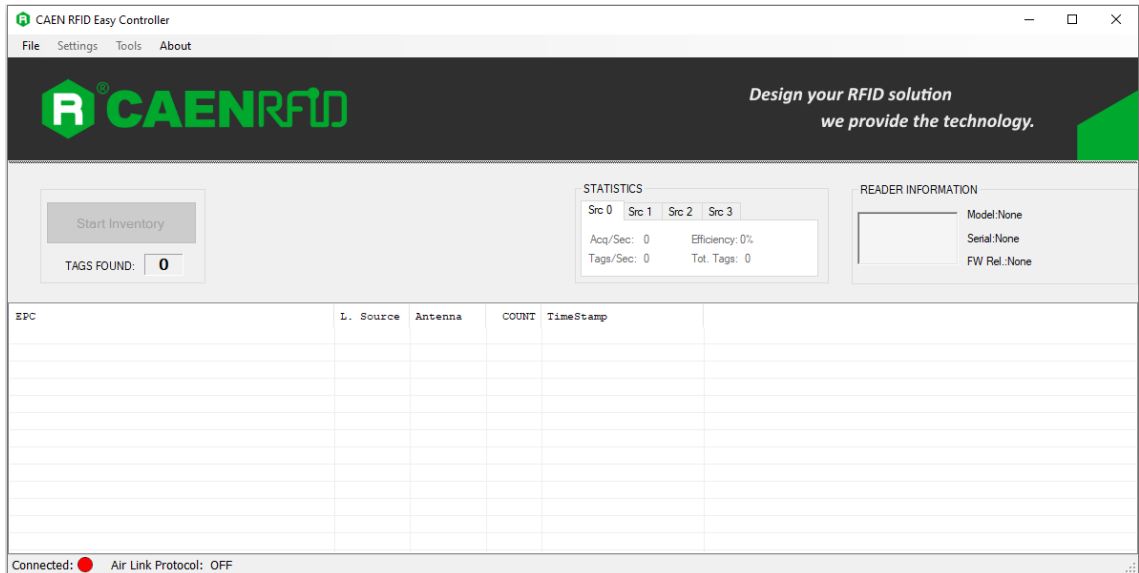

- On the main screen click on File → Connect. A Connection window will open. Select the Connection Type (RS232) and specify the RS232 port (COM 5 in this example):

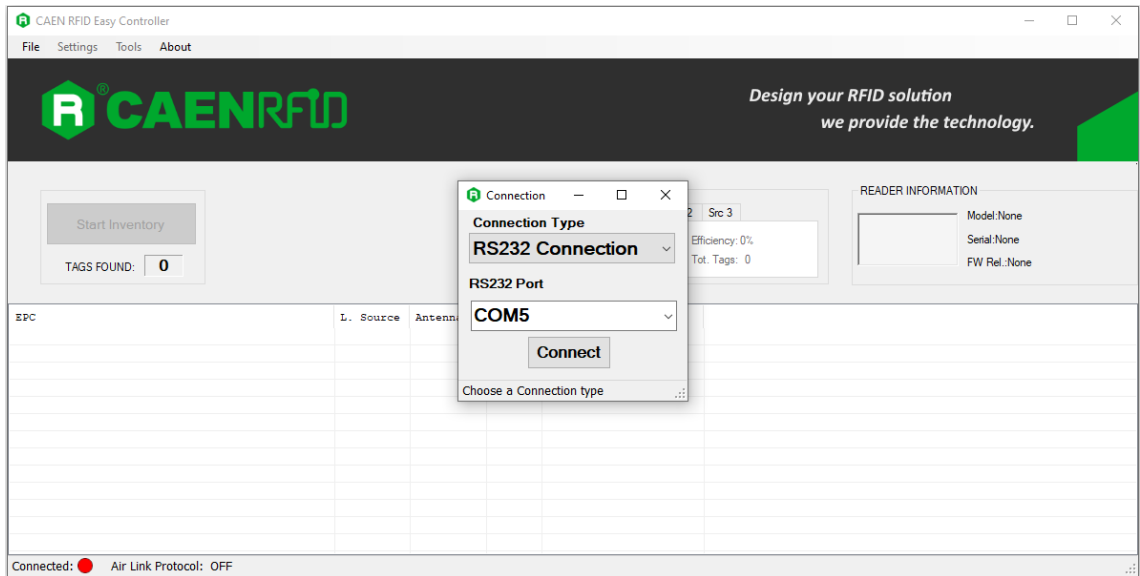

- To verify if the connection with the reader has been established, check the green dot on the bottom left side of the sidebar and on the READER INFORMATION box you can find information on reader model, serial number and firmware release:

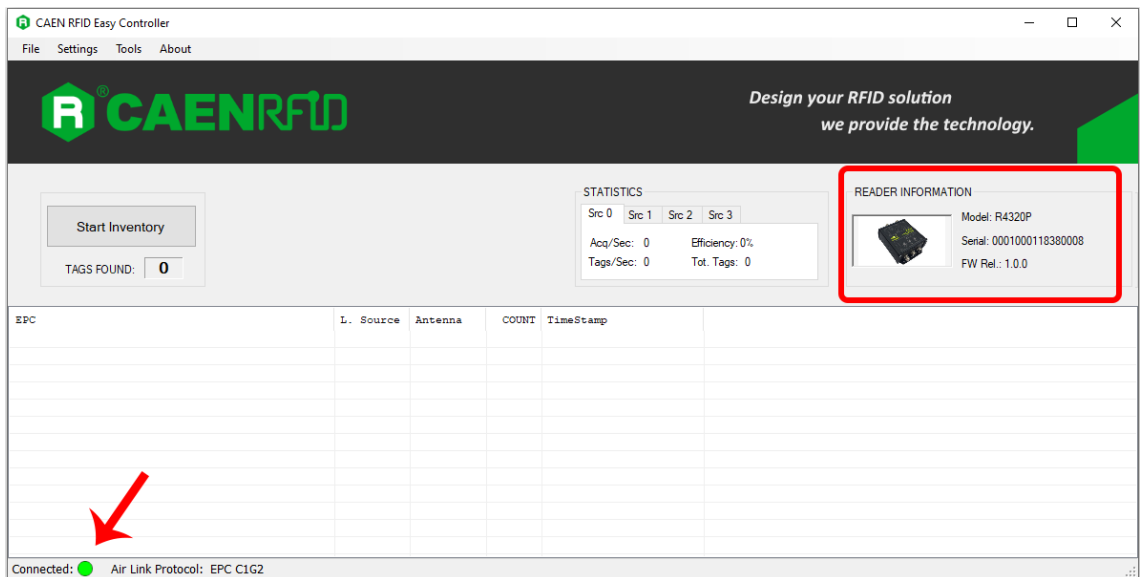

- Place a tag on the read range of the reader, click on *start inventory* and see the tag information displayed on the main window:

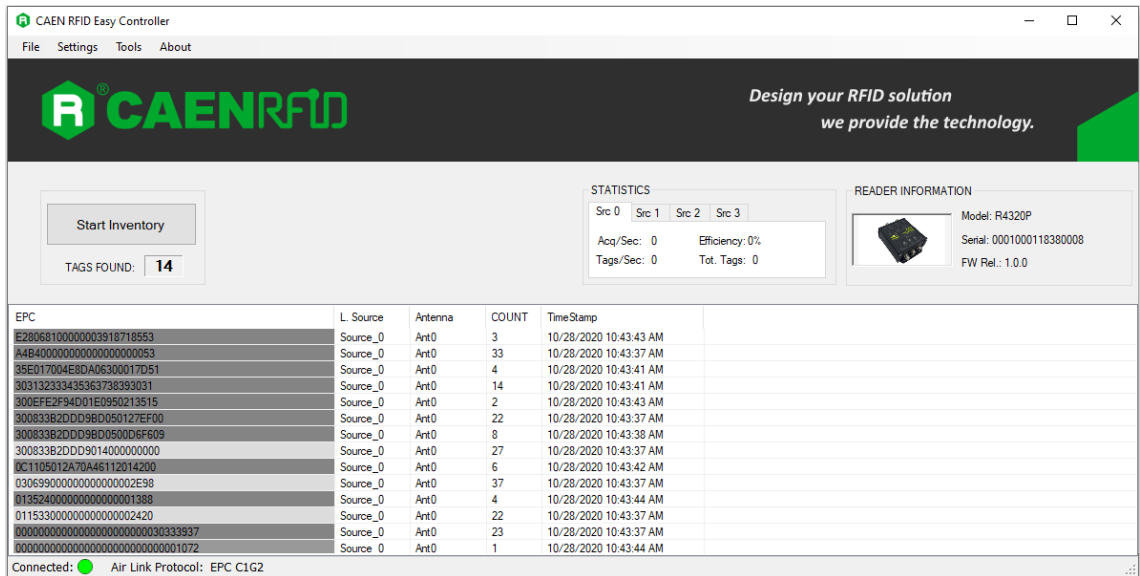

For more information on the CAEN RFID *Easy Controller for Windows* application usage, please refer to the relevant user manual: you can download it from the [Proton R4320P web page](#), *Downloads* section or in the [Manual and Documents](#) web area.

Inventory on GPIO state change

This mode has been designed to enable the inventory at the change of state of the GPIO0 and GPIO1 as illustrated in the paragraph *Input signal* page 19. The inventory is executed until the state change persists.



In the easy2read profile it is necessary a **double** activation to perform the inventory on GPIO state change:

1. Activation **via web interface** (see § *Easy2read* page 29)
2. Activation **via Easy Controller Software**:
 - a. Connect the reader to the Easy Controller software. On the main menu of the application, click on *Settings* → *Options*:

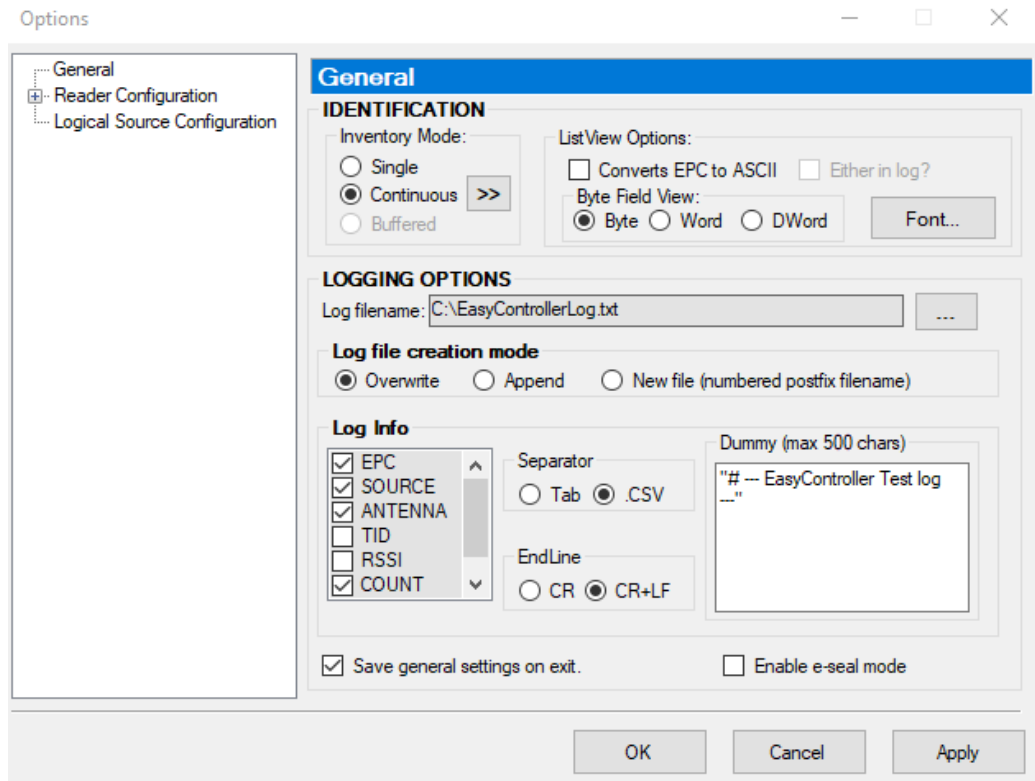

- b. By clicking on  button in the Identification box, you can access the Continuous Inventory Options window:

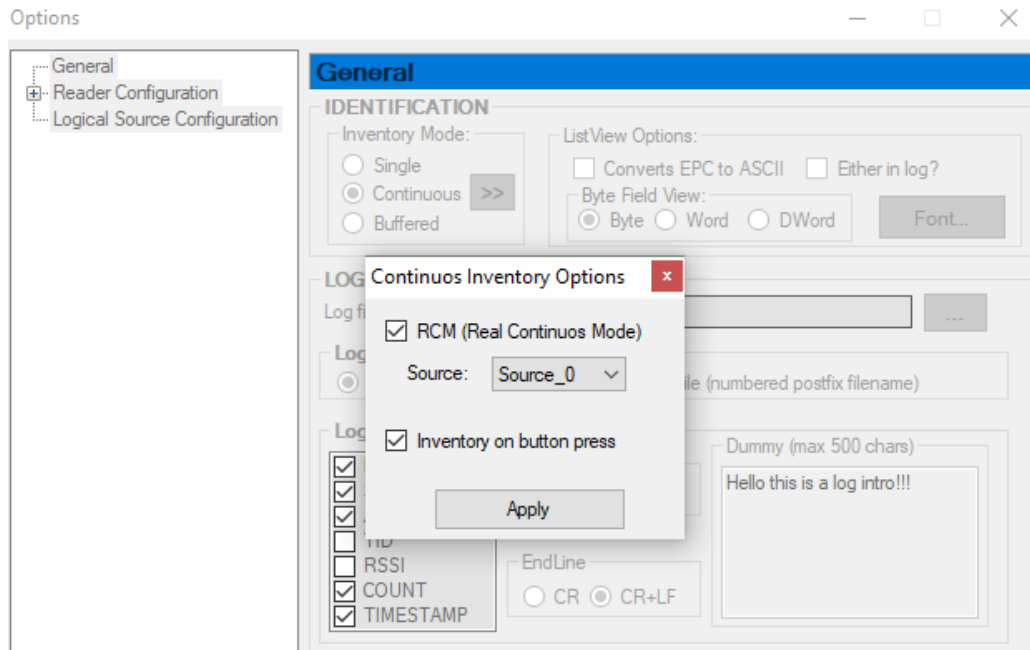

- c. Select the *RCM (Real Continuous Mode)* to perform continuous mode (i.e., a continuous inventory via hardware on the source indicated by the RCM Source parameter) and the *Inventory on button press*. Click on *Apply*. Now click on *Start Inventory* on the main window:

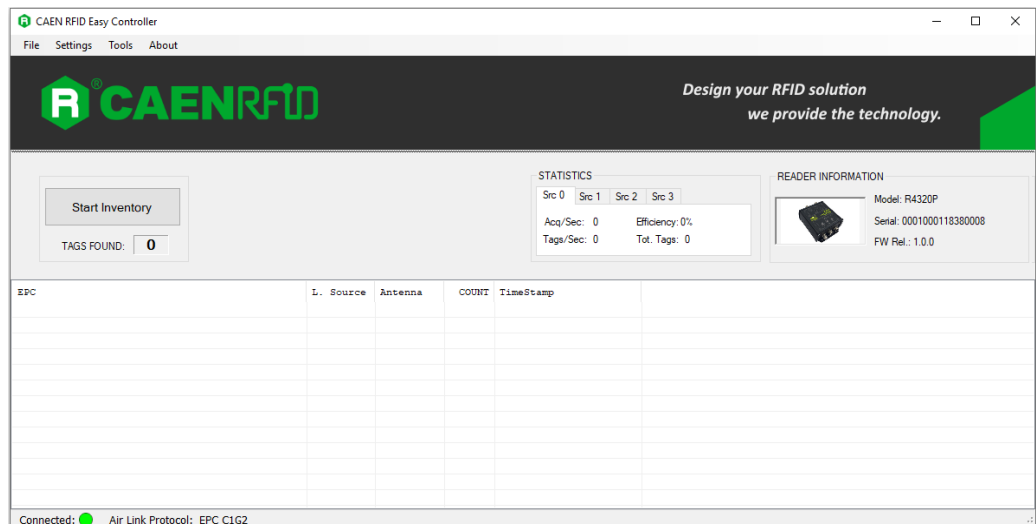

- d. Now the tag inventory is performed at the change of state of the GPIO0/1.

For more information on the CAEN RFID *Easy Controller for Windows* application usage, please refer to the relevant technical information manual: you can download it from the [Proton R4320P web page](#), [Downloads](#) section or in the [Manuals and Documents](#) web area.

6 HID PROFILE

Introduction



Warning: By default the reader is in the easy2read profile.

If your reader is in the **EASY2READ** or **CUSTOM** profile active, in order to set the HID profile, please refer to § *Profile* paragraph page 28.



Warning: Note that, when configured in the HID profile, the Proton R4320P reader cannot be controlled using the *CAEN RFID Easy Controller Application*.

To configure the reader when using the HID profile please refer to the § *HID Configuration Options* paragraph page 31.

The Proton reader can be connected to a PC using an Ethernet cable or the serial port.

Connecting using the Ethernet port

Ethernet Communication Setup

The Proton reader can be connected to a PC using an Ethernet cable. In order to correctly operate with the reader follow the steps above:

1. Connect the Proton to the power supply, the power LED will turn on, wait about 30 seconds until you hear a beep, wait 10 seconds again and the reader is ready to work with the HID profile active.
2. Plug an Ethernet cable (not provided, see § *Ordering Options* page 9) into your computer and connect the other end of the Ethernet cable to the reader. By default, the Proton reader is configured with the static IP address 192.168.0.2. If your private network matches the default network configuration of the reader you can connect to it. Otherwise you can either change the network configuration of the reader (see § *NETWORK* page 26) to connect it to your network or disconnect your PC from your network and connect it to the network of the reader.
3. Connect the antenna cable to Ant-0 (see § *Fig. 3.12: Proton R4320P Antennas* page 22) of the reader.

Now you can use a custom server or existing servers available on the web (e.g. restdb.io) to work with your Proton R4320P reader.

Note that the EPCs of the tags are shown in the format defined in the § *EPC code parameters* paragraph page 34 (configuration via web interface): using the *Tab. 4.3: EPC Code parameters* page 34 you can customize the text of the EPC code displayed on the screen.

Connecting using the serial port

Serial Communication Setup



Warning: If your PC is running a Windows version older than Windows 10, in order to correctly operate with the reader, you need to install the *Gadget Serial USB driver*. You can download it for Windows based systems from the [Proton R4320P web page, Downloads section](#) or from the [Software and Firmware download area](#).

1. Connect the Proton to the power supply, the power LED will turn on, wait about 30 seconds until you hear a beep, wait 10 seconds again and the reader is ready to work with the easy2read profile active.
2. Connect the Proton to the I/O-Serial cable (not provided). Make the connections as indicated in the paragraph *RS232 Communication* page 21 (example of serial connection between the reader and a PC).
3. Connect the antenna cable to Ant-0 (see § *Fig. 3.12: Proton R4320P Antennas* page 22) of the reader.
4. If you use a native COM PORT of the PC, connect to the COM assigned by the operating system.

Otherwise if you use a USB-SERIAL converter go to *Control Panel* → *Hardware and Sound* → *Devices and Printers*. Look at the COM port number assigned to the USB/serial converter.

Now you can use a custom application or an open-source terminal emulator program (e.g. as Tera Term) to work with your Proton R4320P reader.

Note that the EPCs of the tags are shown in the format defined in the § *EPC code parameters* paragraph page 34 (configuration via web interface): using the *Tab. 4.3: EPC Code parameters* page 34 you can customize the text of the EPC code displayed on the screen.

7 CUSTOM PROFILE

Introduction

The use of the *Custom* profile allows the user to upload his own scripts to the reader.



Warning: By default the reader is in the easy2read profile.

If your reader is in the **HID** or **EASY2READ** profile active, in order to set the CUSTOM profile, please refer to § *Profile* paragraph page 28.

To configure the reader when using the CUSTOM profile please refer to the § *Custom Configuration Options* paragraph page 38.

Java Virtual Machine

The user can write his own scripts in Java code and use the "Package Upload " function of the *SYSTEM* section page 27 of the web configuration to upload them on the reader. The selection of the script to be used among those loaded is done through the "Code" option of the § *Custom* section page 32.

To use the uploaded script, the user needs a Java Virtual Machine. Contact the CAEN RFID support to obtain the Virtual Machine and the guideline to its use.

8 READER RESET

It is possible to reset the reader in three different ways:

1. Turn off the reader (disconnect the power supply), **wait about 10 seconds** then turn on the reader again (connect the power supply). Wait for the reboot to be completed.
or
2. Connect the reader to the Web Interface (for more info see § *Configuration Using the Web Interface* page 24), select the *SYSTEM* option and then click on the "Reboot" button. Wait for the reboot to be completed.
or
3. Press the RESET/UPGRADE button for three seconds (see § *Connectors* page 15) until the green power LED turn off. When the LED is off, it means that the reader has been reset and the button can be released. Wait for the reboot to be completed.

9 FIRMWARE UPGRADE

The Proton R4320P firmware upgrade can be performed only via serial port.

In order to upgrade the firmware follow the steps described below:

1. Connect the Proton to the power supply, the power LED will turn on, wait about 30 seconds until you hear a beep, wait 10 seconds again and the reader is ready to work.
2. Connect the Proton to the I/O-Serial cable (not provided). Make the connections as indicated in the paragraph *RS232 Communication* page 21 (example of serial connection between the reader and a PC).
3. Connect to the PC a USB/Serial converter with a transfer rate up to 1Mbps.
4. In your PC, go to *Control Panel* → *Hardware and Sound* → *Devices and Printers*. Look at the COM port number assigned to the USB/Serial converter when detected.
5. Hold down the reset button (see § *Tab. 3.2: Proton R4320P Interfaces Panel* page 15) for about 20 seconds to enter the "upgrade mode".
6. Download the *Proton Upgrade Tool* and the *firmware image file* at the [Proton R4320P web page](#) of the CAEN RFID Web Site, *Downloads* section.
7. Open the FW upgrade program and click on "Next":



8. Select the COM port number assigned to the USB/Serial converter, upload the FW image file by clicking on the “Browse” button and click on the “Upgrade Firmware” button:

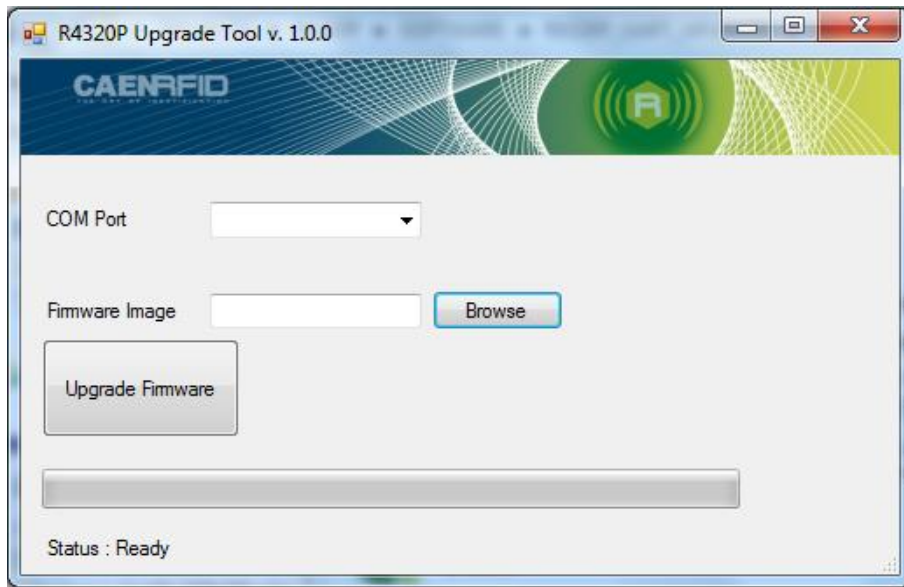

9. Wait for the upgrade process to be completed. In the window you will see the message “Status: upgrading”.
At the end of procedure, if the upgrade has been successfully performed, you will see the message “Status: ready”.
10. Turn off the reader (disconnect the power supply), **wait about 10 seconds** and then turn on the reader again (connect the power supply). Now the reader is ready to work with the new firmware upgraded.



Warning: The firmware upgrade is a factory reset: all the scripts uploaded into the reader are deleted.

10 TECHNICAL SPECIFICATIONS

Technical Specifications Table

Frequency Range	<ul style="list-style-type: none"> – 865.600÷867.600 MHz (ETSI EN 302 208 v3.1.1) – 902÷928 MHz (FCC part 15.247)
RF Power	<ul style="list-style-type: none"> – Up to 31.5 dBm (1.4W) conducted (ETSI) – Up to 30 dBm (1W) conducted (FCC)
Number of Channels	<ul style="list-style-type: none"> – 4 channels (compliant to ETSI EN 302 208 v3.1.1) – 50 hopping channels (compliant to FCC part 15.247)
Standard Compliance	EPC C1G2/ISO 18000-63
CPU	ARM9 @ 400MHz on Atmel AT91SAM9G25
Operating system	Linux
Receiving Capability	<ul style="list-style-type: none"> – Gen 2 Dense Reader Mode Management – Data rate up to 400 Kb/s
Connectivity	<ul style="list-style-type: none"> – RS232 Serial Communication (M12 connector) <ul style="list-style-type: none"> ▪ Baudrate up to 115.200kbps ▪ Databits: 8 ▪ Stopbit: 1 ▪ Parity: none ▪ Flow control: none – Ethernet 10/100/1000BASE-T (M12 connector) – PoE standard IEEE 802.3af
I/O Interface	<ul style="list-style-type: none"> – M12 connector – 2 digital inputs optically isolated – 2 solid state photorelay outputs optically isolated (500mA max)
Antenna Connectors	4 TNC Reverse Polarity
Power Supply	<ul style="list-style-type: none"> – 9÷36V DC power supply (12W) – PoE standard IEEE 802.3af (12,95W)
Visual Status Indicators	Multicolor LEDs: Power, Activity, Status and Applications
Operating Temperature	-10°C to +55°C
IP Rating	IP65 ⁵
Dimensions	<ul style="list-style-type: none"> – (W)131 x(L)106 x (H)50 mm³ – (5.15 x 4.17 x 1.96 inch³)
Weight	530 g

Tab. 10.1: Proton R4320P Technical Specifications



Warning: The RF settings must match the operating country/region to comply with local laws and regulations.

The usage of the reader in different countries/regions from the one in which the device has been sold is not allowed.

⁵ Warning: To guarantee the IP65 degree of the device, the antennas must all be wired. If the connector is free, a protective cap must be applied to guarantee the IP65 degree.

Technical Drawings

The following drawings show the Proton R4320P reader from different points of view.
All dimensions are in millimeters.

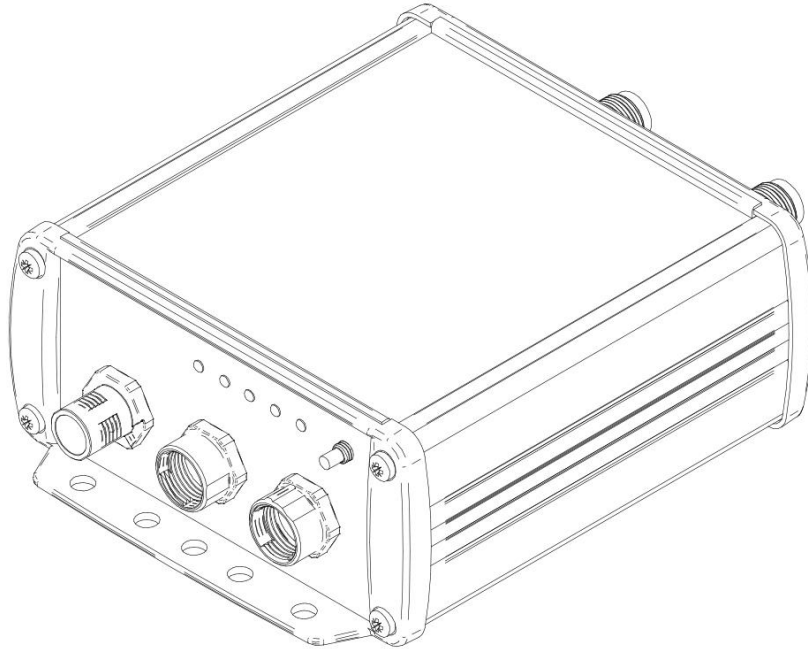

Fig. 10.1: Proton R4320P Technical Drawings – 3D view

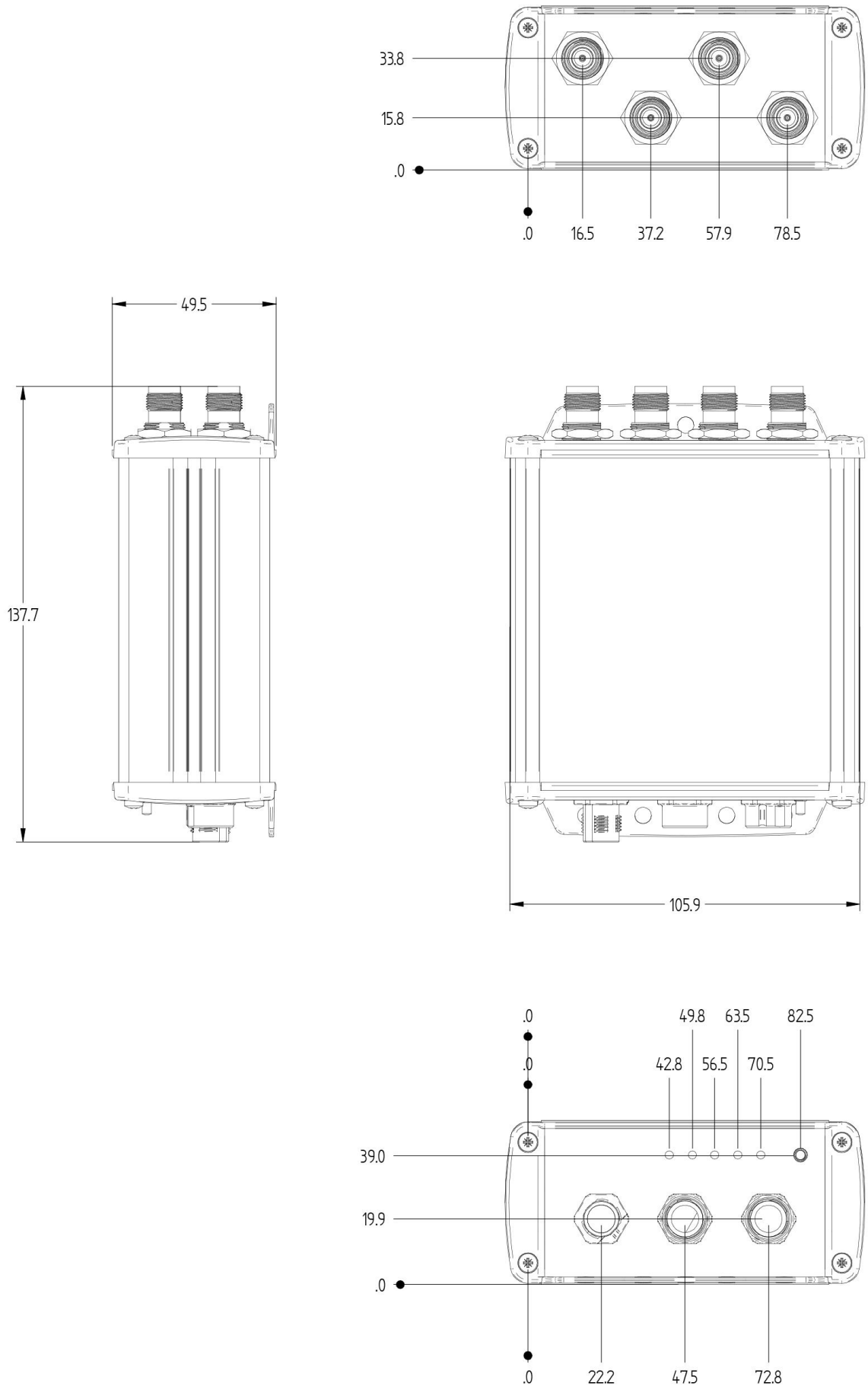

Fig. 10.2: Proton R4320P Technical Drawings

11 CONNECTING TO RA0003 MULTIPLEXER

RA0003 Multiplexer

The [RA0003](#) module is a 1 to 4 UHF antenna multiplexer that allows to expand read points management of CAEN RFID easy2read product line.

Typical usages of the device is the extension of number of read points of multiantenna reader like Proton R4320P for smart shelves installations, manufacturing lines and all others applications requiring a large number of antennas to be connected.

RA0003 has SMA RF connectors, is able to manage up to 2W RF power and can be used in the whole range of UHF RFID worldwide band.

The module has a extended supply voltage range (9Vdc – 36Vdc) and TTL level address signal.

Five LEDs provide the user with information about module operation.



Fig. 11.1: RA0003 UHF Antenna Multiplexer

Proton R4320P – RA0003 Multiplexer Connection

Depending on how the reader is powered, we can distinguish two cases of connection to the RA0003 multiplexer:

- Case 1: Proton R4320P reader powered by 9/36V DC power supply
- Case 2: Proton R4320P reader powered via POE

CASE1:

The figure below shows how to connect the Proton R4320P reader to the RA0003 multiplexer when the reader is powered by the supplied 9/36V DC power supply:

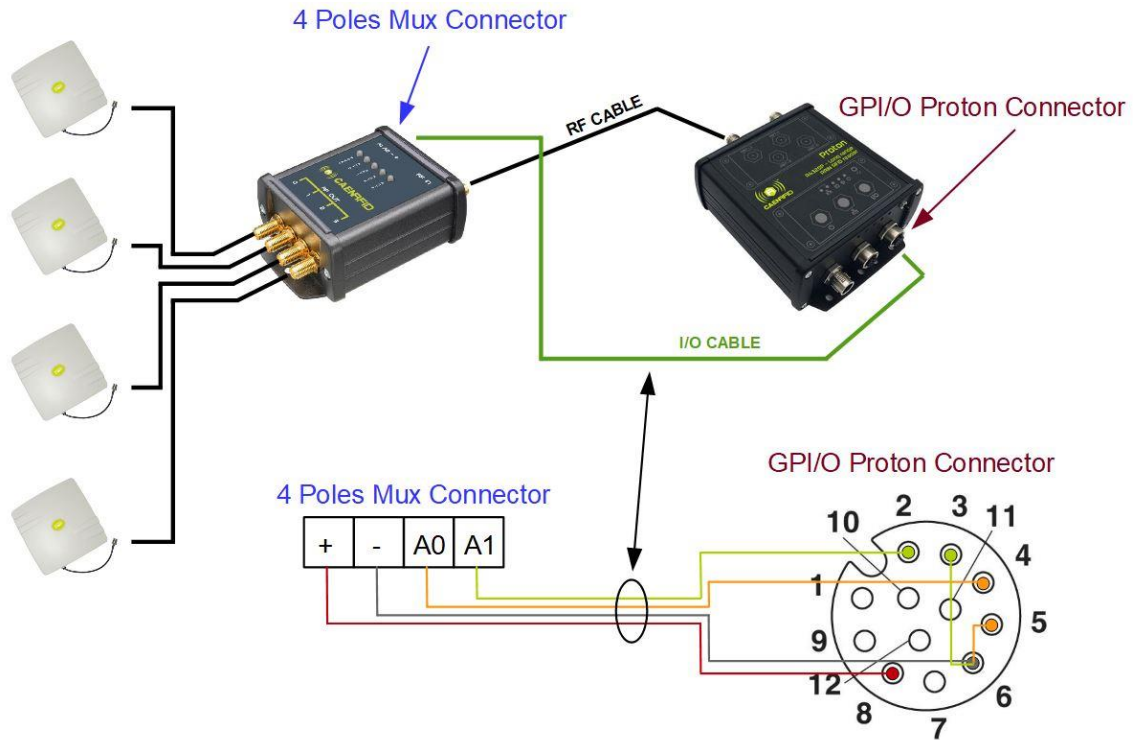

Fig. 11.2: Proton reader – RA0003 MUX Connection- case 1

The GPIO/Serial cable is not provided. We suggest to use the products described in § *GPIO/Serial* paragraph page 18.

GPIO Proton CONNECTOR			MUX CONNECTOR	
pin 8 : V_INT		→	pin 1 : V _{in}	
pin 6 : GND		→	pin 2 : GND	
pin 2 : OUTPUT2.2		→	pin 4 : A1	
pin 3 : OUTPUT2.1		→	pin 2 : GND	
pin 4 : OUTPUT1.2		→	pin 3 : A0	
pin 5 : OUTPUT1.1		→	pin 2 : GND	

By enabling the relay contact (as described in the § *GPIO/Serial* paragraph page 18), pin A0 - A1 are connected to GND (low logic level) enabling the antennas according to this table:

A1	A0	Signal Path
Low	Low	IN connected to OUT0
Low	High	IN connected to OUT1
High	Low	IN connected to OUT2
High	High	IN connected to OUT3

CASE 2:

The figure below shows how to connect the Proton R4320P reader to the RA0003 multiplexer when the reader is powered via POE:

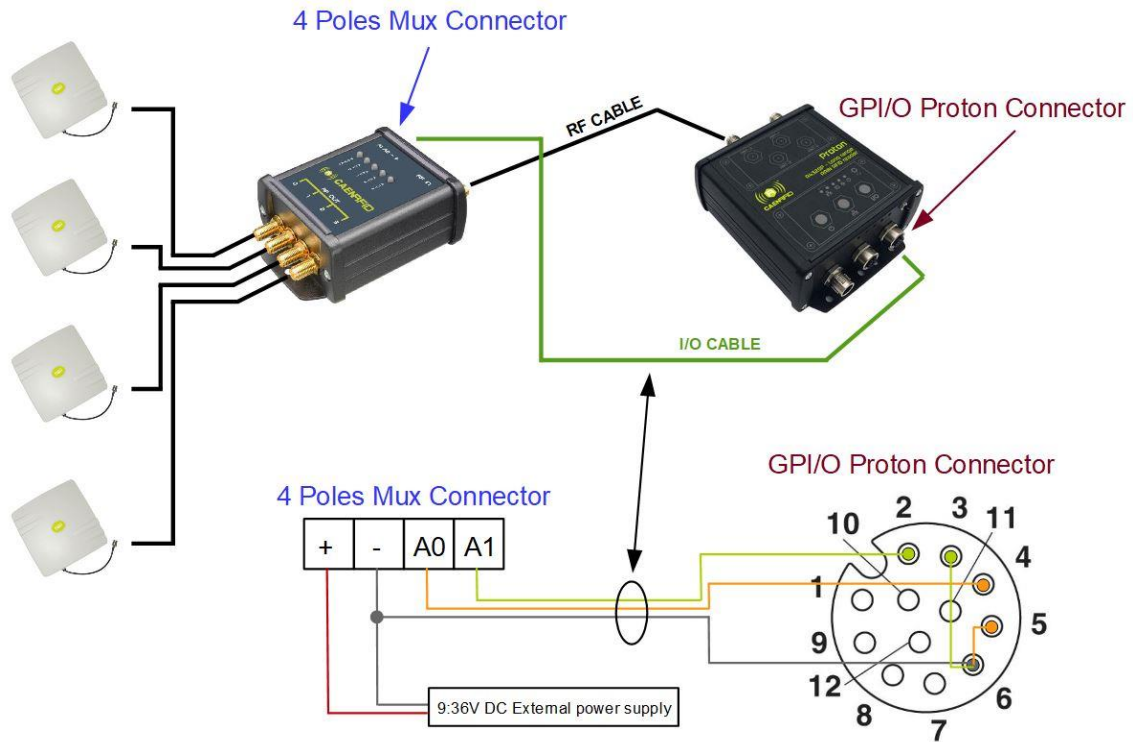

Fig. 11.3: Proton reader – RA0003 MUX Connection – case 2



Warning: If the Proton is powered via POE, the voltage present on pin 8 (V_int) is equal to 5V and it is not sufficient to power the multiplexer (range 9:36 V). An external power supply is required. The power supply is available upon request.

The GPIO/Serial cable is not provided. We suggest to use the products described in § GPIO/Serial paragraph page 18.

GPIO Proton CONNECTOR		MUX CONNECTOR
pin 6 : GND	→	pin 2 : GND
pin 2 : OUTPUT2.2	→	pin 4 : A1
pin 3 : OUTPUT2.1	→	pin 2 : GND
pin 4 : OUTPUT1.2	→	pin 3 : A0
pin 5 : OUTPUT1.1	→	pin 2 : GND

9:36 DC EXTERNAL POWER SUPPLY		MUX CONNECTOR
pin + : Positive	→	pin 1 : Vin
pin - : Negative	→	pin 2 : GND

By enabling the relay contact (as described in the § GPIO/Serial paragraph page 18), pin A0 - A1 are connected to GND (low logic level) enabling the antennas according to this table:

A1	A0	Signal Path
Low	Low	IN connected to OUT0
Low	High	IN connected to OUT1
High	Low	IN connected to OUT2
High	High	IN connected to OUT3

12 REGULATORY COMPLIANCE

CE Compliance

Reference standard:

ETSI EN 301 489-1 V2.2.0:2017

ETSI EN 301 489-3 V2.1.1:2017

EN 55032:2015

ETSI EN 302 208 V3.1.1:2017

EN 62368-1:2014 +/-AC:2015 +/-A11:2009 +/-A1:2010 +/-A2:2013 +/-A12:2011

See § **PROTON R4320P CE DECLARATION OF CONFORMITY** page 63 for the Proton R4320P CE Compliance Certificate.



Warning: The CE compliance is guaranteed only if the reader is used as described in this manual

FCC Compliance

This equipment has been tested and found to comply with the limits for a Class B digital device, pursuant to Part 15 of the FCC Rules. These limits are designed to provide reasonable protection against harmful interference in a residential installation.

This equipment generates uses and can radiate radio frequency energy and, if not installed and used in accordance with the instructions, may cause harmful interference to radio communications. However, there is no guarantee that interference will not occur in a particular installation. If this equipment does cause harmful interference to radio or television reception, which can be determined by turning the equipment off and on, the user is encouraged to try to correct the interference by one of the following measures:

- a. Reorient or relocate the receiving antenna.
- b. Increase the separation between the equipment and receiver.
- c. Connect the equipment into an outlet on a circuit different from that to which the receiver is connected.
- d. Consult the dealer or an experienced radio/TV technician for help.

This device complies with Part 15 of the FCC Rules. Operation is subject to the following two conditions: (1) This device may not cause harmful interference, and (2) this device must accept any interference received, including interference that may cause undesired operation.

Any changes or modification not approved by CAEN RFID could void the user's authority to operate the equipment.

The device shall be used with CAEN RFID antenna Mod. WANTENNAX020 Circular polarized antenna FCC with 5.5dBi gain.

The device shall be used such that a minimum separation distance of 25cm is maintained between the reader and user's/nearby people's body.

Reference documents:

Test report n. R19237901 [RD2] and n. R19238001 [RD3].

See § *PROTON R4320P FCC GRANT* page 64 for the Proton R4320P FCC Compliance Certificate.

RoHS EU Directive

The Proton R4320P RAIN RFID reader is compliant with the EU Directive 2015/863/EU on the Restriction of the Use of certain Hazardous Substances in Electrical and Electronic Equipment (RoHS3).

PROTON R4320P

CE DECLARATION OF CONFORMITY

We

CAEN RFID Srl
Via Vetraia, 11
55049 Viareggio (LU)
Italy
Tel.: +39.0584.388.398 Fax: +39.0584.388.959
Mail: info@caenrfid.com
Web site: www.caenrfid.com

herewith declare under our own responsibility that the product:

Code: WR4320PXAAA
Description: R4320P Proton - Compact 4 - port UHF RFID Reader

corresponds in the submitted version to the following standards:

ETSI EN 301 489-1 V2.2.0:2017
ETSI EN 301 489-3 V2.1.1:2017
EN 55032:2015
ETSI EN 302 208 V3.1.1:2017
EN 62368-1:2014 +/AC:2015 +/A11:2009 +/A1:2010 +/A2:2013 +/A12:2011

and declare under our sole responsibility that the specified product meets the principle requirements and other applicable regulations of directives 2014/53/EU (RED) and 2015/863/EU (RoHS3)

Date: 01/04/2021

A handwritten signature in blue ink over a printed stamp.

CAEN RFID Srl
Via Vetraia, 11
55049 VIAREGGIO - ITALY
VAT IT 02032050466

Adriano Bigongiari (Chief Executive Officer)

On the basis of this declaration, this product will bear the following mark:



PROTON R4320P FCC GRANT

TCB

**GRANT OF EQUIPMENT
AUTHORIZATION**

TCB

**Certification
Issued Under the Authority of the
Federal Communications Commission
By:**

**EMCCons DR RASEK GmbH & Co. KG
Stoernhofer Berg 15
Unterleinleiter, 91364
Germany**

**Date of Grant: 12/17/2019
Application Dated: 12/17/2019**

**CAEN RFID srl
via Vetraia, 11 - 55049 Viareggio (LU) - ITALY
Viareggio, 55049
Italy**

Attention: Adriano Bigongiari , CEO

NOT TRANSFERABLE

EQUIPMENT AUTHORIZATION is hereby issued to the named GRANTEE, and is VALID ONLY for the equipment identified hereon for use under the Commission's Rules and Regulations listed below.

FCC IDENTIFIER: UVECAENRFID028
Name of Grantee: CAEN RFID srl
Equipment Class: Part 15 Class B Digital Device
Notes: R4320P - PROTON - Long range RAIN RFID reader

<u>Grant Notes</u>	<u>FCC Rule Parts</u>	<u>Frequency Range (MHZ)</u>	<u>Output Watts</u>	<u>Frequency Tolerance</u>	<u>Emission Designator</u>
	15B				

